

ENGLISH

**DDL-8700B-7
INSTRUCTION MANUAL**

CONTENTS

I. SPECIFICATIONS	1
II. SET-UP	3
1. Installation	3
2. Installing the pedal sensor.....	4
3. Connecting the connector	4
4. How to install the power plug	5
5. Attaching the connecting rod	5
6. Winding the bobbin thread	6
7. Adjusting the height of the knee lifter.....	7
8. Installing the thread stand	7
9. Lubrication	8
10. Adjusting the amount of oil (oil splashes).....	8
11. Attaching the needle	10
12. Setting the bobbin into the bobbin case	11
13. Adjusting the stitch length.....	11
14. Presser foot pressure.....	11
15. Hand lifter	11
16. Adjusting the height of the presser bar	12
17. Threading the machine head	12
18. Thread tension	13
19. Thread take-up spring	13
20. Adjusting the thread take-up stroke	13
21. Needle-to-hook relationship	14
22. Height of the feed dog	14
23. Tilt of the feed dog.....	15
24. Adjusting the feed timing.....	15
25. Counter knife.....	16
26. Pedal pressure and pedal stroke.....	16
27. Adjustment of the pedal	17
28. Marker dots on the handwheel	17
III. FOR THE OPERATOR	18
1. Operating procedure of the sewing machine.....	18
2. Setting procedure of the machine head	19
3. Operation panel built in the machine head	20
4. Operating procedure of the sewing pattern	21
5. One-touch setting	23
6. Setting of functions	24
7. Production support function	25
8. Function setting list.....	27
9. Detailed explanation of selection of functions	31
10. Automatic compensation of neutral point of the pedal sensor.....	41
11. Selection of the pedal specifications	42
12. Setting of the auto lifter function	42
13. Selecting procedure of the key-lock function.....	43
14. Initialization of the setting data	43
15. LED hand light.....	44
16. Height adjustable one-touch type reverse stitching switch	44
IV. MAINTENANCE	45
1. Adjusting the machine head	45
2. Error codes	46

I. SPECIFICATIONS

Supply voltage	3-phase 200 to 240V	Single phase 220 to 240V
Frequency	50Hz/60Hz	50Hz/60Hz
Operating environment	Temperature : 5 to 35°C Humidity 35 - 85 % or less	Temperature : 5 to 35°C Humidity 35 - 85 % or less
Input	210VA	210VA

DDL-8700B Δ -7

S :	Light- to Medium-weight materials
H :	Heavy-weight materials

	DDL-8700BS-7	DDL-8700BH-7
Application	Light- to Medium-weight materials	Heavy-weight materials
	(Schematic drawing of the applicable range)  Light-weight materials ← → Heavy-weight materials	
Max. sewing speed	5,000 sti/min	4,000 sti/min
Thread trimming speed	300 sti/min	300 sti/min
Stitch length	4 mm	5 mm
Presser foot lift (by knee lifter)	13 mm	13 mm
Needle *1	DB x 1 (#14) #9 to 18	DB x 1 (#21) #20 to 23
Lubricating oil	JUKI MACHINE OIL #7	JUKI MACHINE OIL #7

• The sewing speed preset at the time of shipping : 4,000sti/min.

*1 : Needle used depends on the destination.

Noise	- Equivalent continuous emission sound pressure level (L _{pA}) at the workstation : A-weighted value of 79.5 dB; (Includes K _{pA} = 2.5 dB); according to ISO 10821- C.6.2 -ISO 11204 GR2 at 4,000 sti/min.
-------	-----------------------------------------------------------------------------------------------------------------------------------------------------------------------------------------------------------------------------------

DRAWING OF TABLE

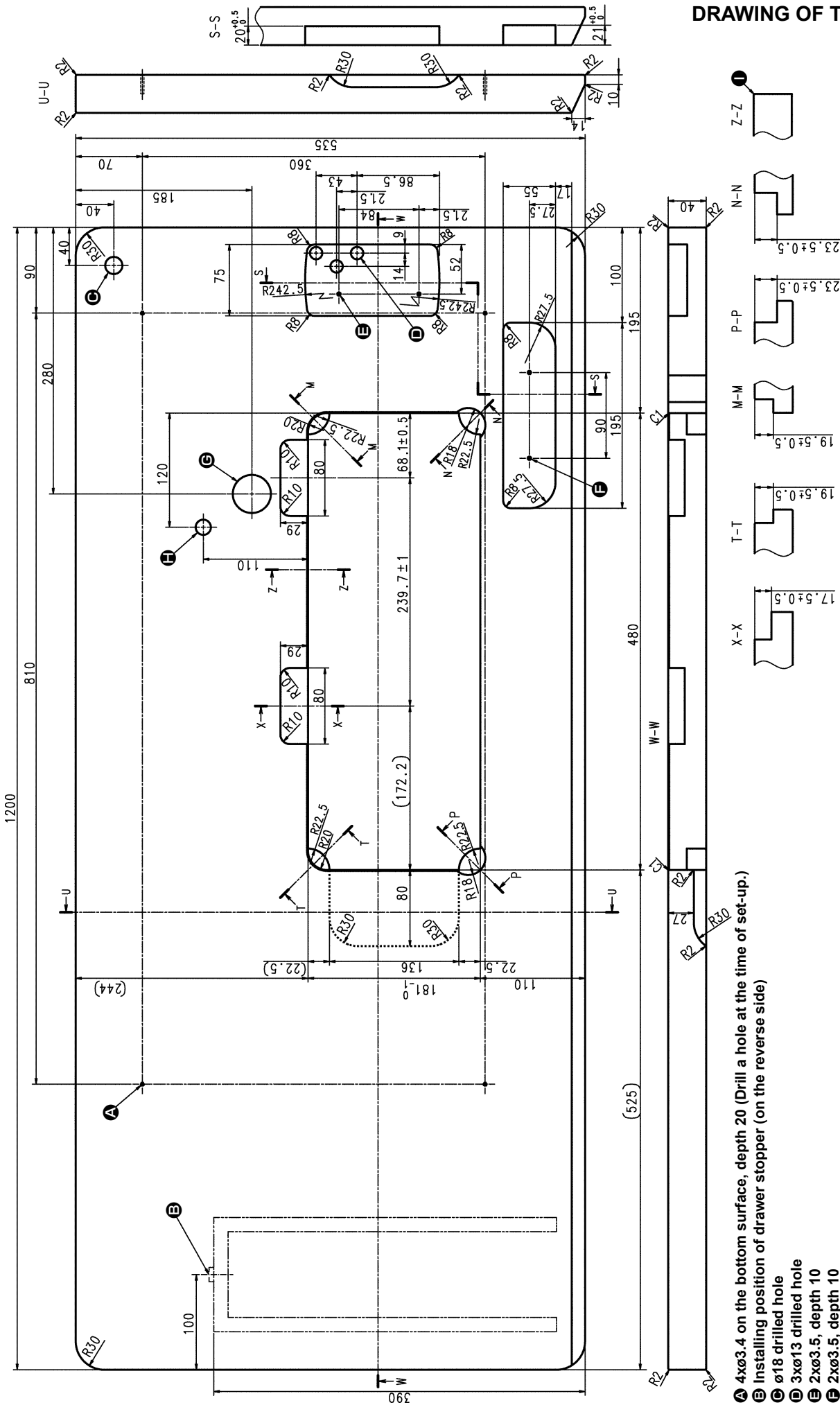

- A 4xø3.4 on the bottom surface, depth 20 (Drill a hole at the time of set-up.)
- B Installing position of drawer stopper (on the reverse side)
- C ø18 drilled hole
- D 3xø13 drilled hole
- E 2xø3.5, depth 10
- F 2xø3.5, depth 10
- G ø40±0.5 drilled hole
- H ø16 depth 30
- I C1.5 to C2.5 (hinge side only)

II. SET-UP

1. Installation

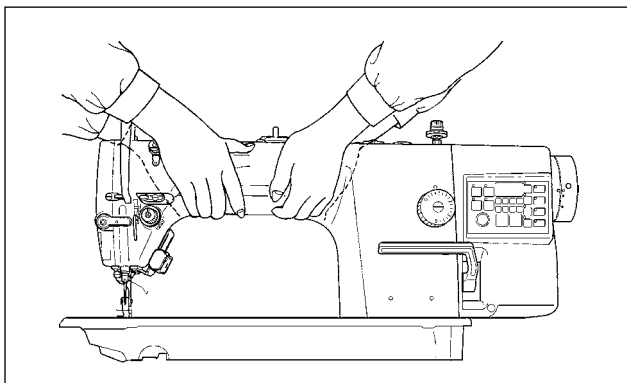

1) Carry the sewing machine with two persons as shown in the figure above.

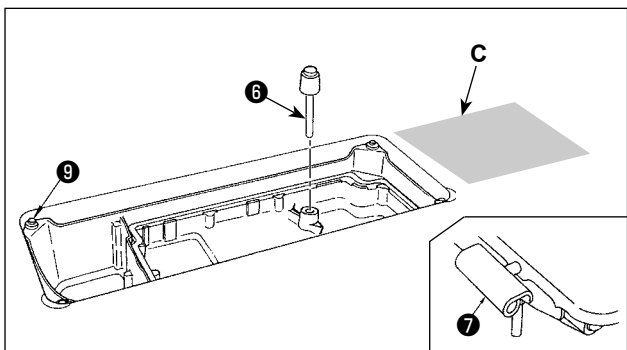
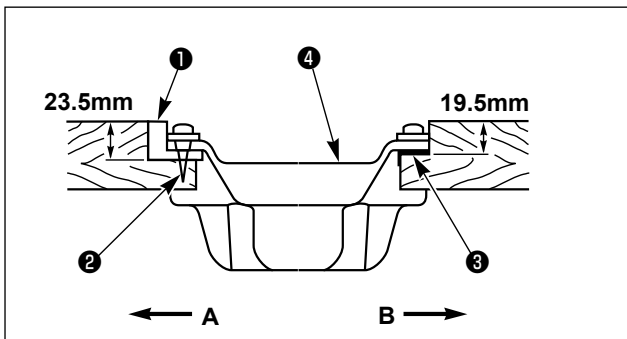
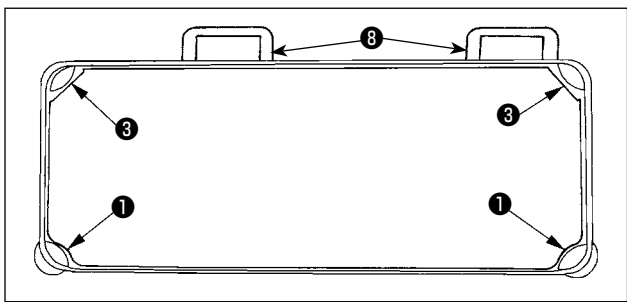
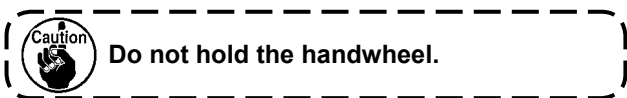

- 5) Fit knee lifter pressing rod **6**. Fit hinge **7** into the opening in the machine bed, and fit the machine head to table rubber hinge **8** before placing the machine head on cushions **9** on the four corners.
- 6) Securely attach head support rod **10** to the table until it goes no further.

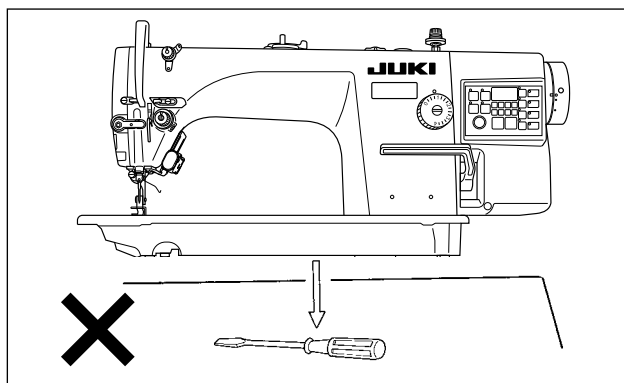
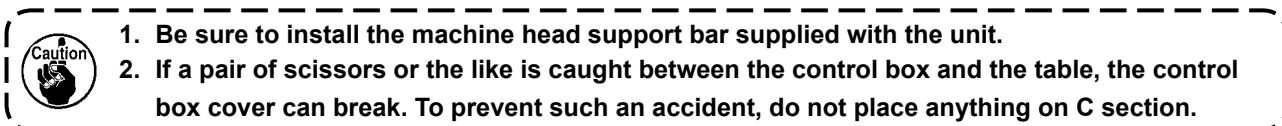

2) Do not put protruding articles such as the screwdriver and the like at the location where the sewing machine is placed.

3) Adjust so that the oil pan is supported at the four corners of the table. Mount rubber hinge seat **8** on the table and fix it on the table with a nail.

4) Two rubber seats **1** for supporting the head portion on the operator side **A** are fixed on the extended portion of the table by hitting the nail **2**, and the other two rubber cushion seats **3** on the hinge side **B** are fixed by using a rubber-based adhesive. Then, oil pan **4** is placed.

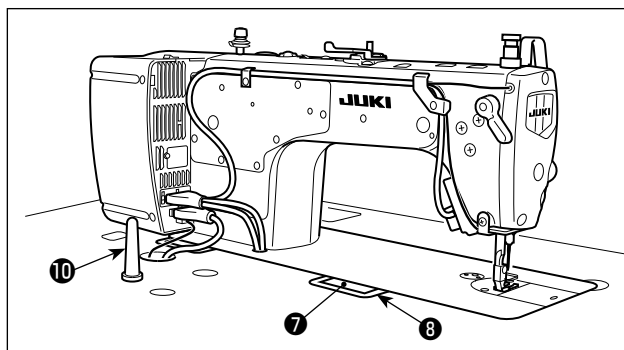

2. Installing the pedal sensor

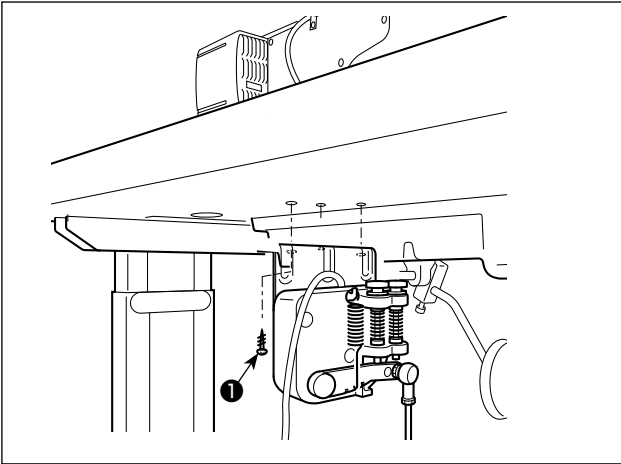

- 1) Install the pedal sensor to the table with mounting screws ❶ supplied with the unit.
It is necessary to install the pedal sensor at such a position that the connecting rod is perpendicular to the table.
- 2) After the completion of installation of the pedal sensor on the table, place the sewing machine head on the table.

3. Connecting the connector

WARNING :

- To protect against personal injury resulting from abrupt start of the sewing machine, be sure to turn the power OFF, unplug the machine and wait for five minutes or more before installing the pedal sensor.
- To prevent damage of device caused by maloperation and wrong specifications, be sure to connect all the corresponding connectors to the specified places. (If any of the connectors is inserted into a wrong connector, not only the device corresponding to the connector can break but also it can start abruptly, inviting the risk of personal injury.)
- To prevent personal injury caused by maloperation, be sure to lock the connector with lock.
- As for the details of handling respective devices, read carefully the Instruction Manuals supplied with the devices before handling the devices.

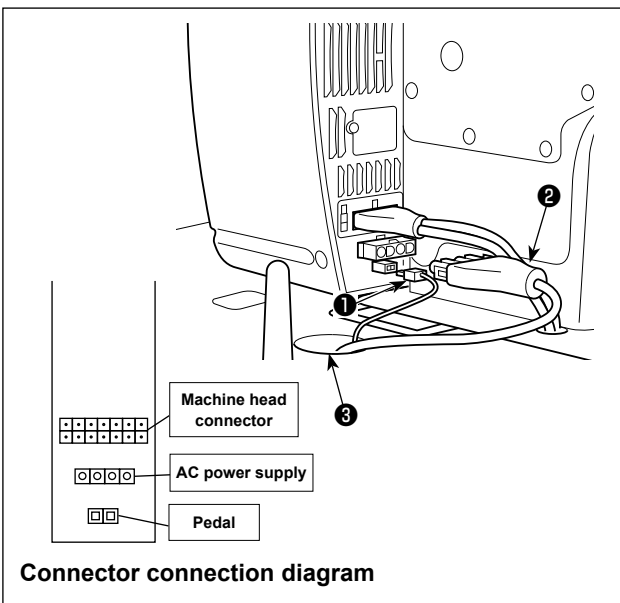

Do not insert the power plug into the wall outlet.
Check to be sure that the power switch is turned OFF.

- 1) Connect pedal sensor cable ❶ and AC input cable ❷ supplied with the machine to the control box. For the connection ports of the cables, refer to the connector layout drawing.



Be sure to fully insert the connectors into the corresponding ports until they are locked.

- 2) Draw out cable of the control box through cable draw-out hole ❸ to route it to the underside of the sewing machine table.

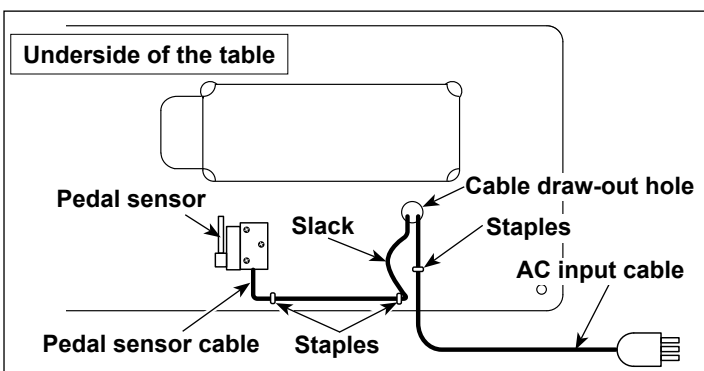

- 3) Fix the pedal cable and AC input cable with a staple.

4. How to install the power plug



WARNING :

1. Be sure to attach the ground wire (green/yellow) to the specified location (on the ground side).
2. Take care not to allow terminals to come in contact with each other.

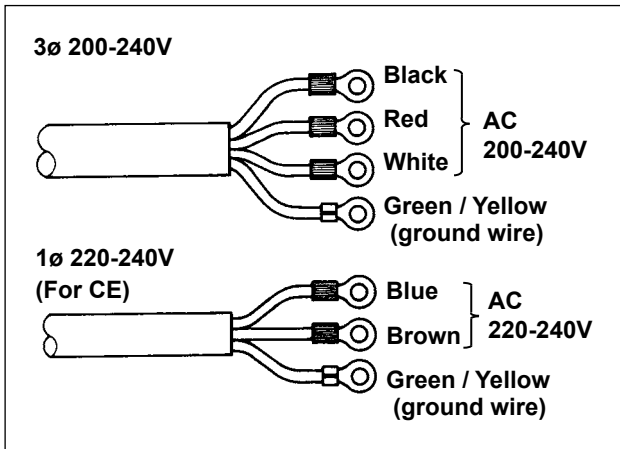

- 1) Connect the power cord to power plug ❶. Connect the black, red and white wires (3 ø) and the blue and brown wires (1 ø) to the power supply side and the green/yellow wire to the earth side as illustrated in the figure.



1. Be sure to prepare the power plug ❶ which conforms to the safety standard.
2. Be sure to connect the ground lead (green/yellow) to the grounding side.

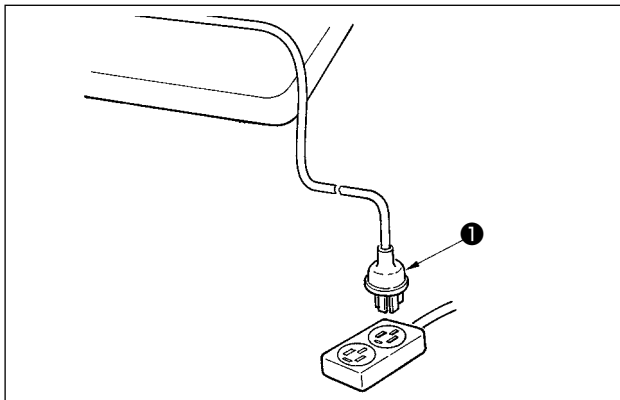

- 2) Check that the power switch is in the OFF state. Then, insert the power plug ❶ coming from the power switch into the plug receptacle.



In prior to the connection of the power plug ❶, re-check the supply voltage specification indicated on the control box.

* The power plug ❶ is different in shape according to the destination of the sewing machine.

5. Attaching the connecting rod



WARNING :

To protect against possible personal injury due to abrupt start of the machine, be sure to start the following work after turning the power off and a lapse of 5 minutes or more.

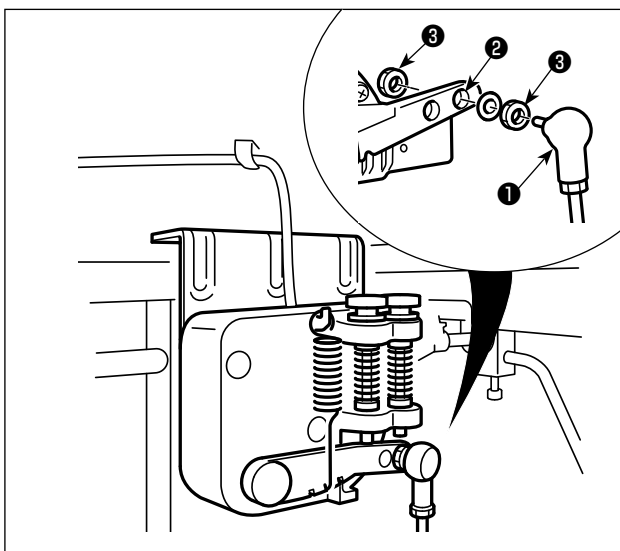

- Fix connecting rod ❶ to installing hole of pedal lever ❷ with nut ❸.

6. Winding the bobbin thread

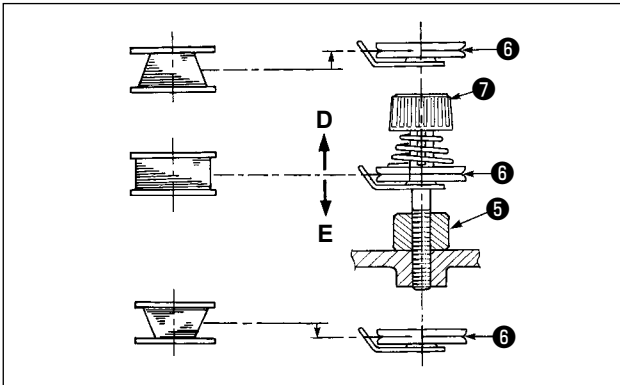
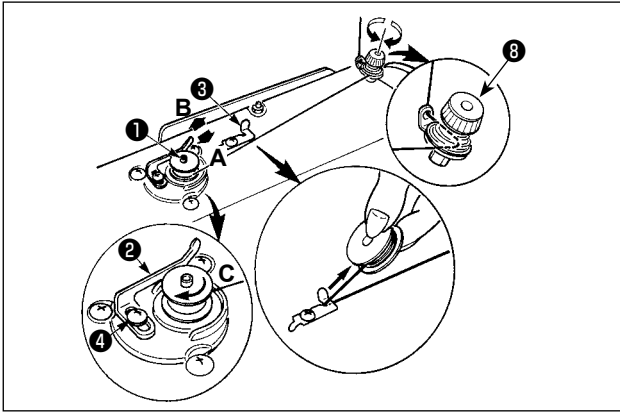

- 1) Insert the bobbin deep into the bobbin winder spindle ① until it will go no further.
- 2) Pass the bobbin thread pulled out from the spool rested on the right side of the thread stand following the order as shown in the figure on the left. Then, wind clockwise the end of the bobbin thread on the bobbin several times.
(In case of the aluminum bobbin, after winding clockwise the end of the bobbin thread, wind counterclockwise the thread coming from the bobbin thread tension several times to wind the bobbin thread with ease.)
- 3) Press the bobbin winder trip latch ② in the direction of **A** and start the sewing machine. The bobbin rotates in the direction of **C** and the bobbin thread is wound up. The bobbin winder spindle ① automatically as soon as the winding is finished.
- 4) Remove the bobbin and cut the bobbin thread with the thread cut retainer ③.
- 5) When adjusting the winding amount of the bobbin thread, loosen setscrew ④ and move bobbin winding lever ② to the direction of **A** or **B**. Then tighten setscrew ④.

To the direction of **A** : Decrease

To the direction of **B** : Increase

- 6) In case that the bobbin thread is not wound evenly on the bobbin, loosen screw ⑤ and adjust the height of bobbin thread tension ③.
 - It is the standard that the center of the bobbin is as high as the center of thread tension disk ⑥.
 - Adjust the position of thread tension disk ⑥ to the direction of **D** when the winding amount of the bobbin thread on the lower part of the bobbin is excessive and to the direction **E** when the winding amount of the bobbin thread on the upper part of the bobbin is excessive.

After the adjustment, tighten screw ⑤.
- 7) To adjust the tension of the bobbin winder, turn the thread tension nut ⑦.



1. When winding the bobbin thread, start the winding in the state that the thread between the bobbin and thread tension disk ⑥ is tense.
2. When winding the bobbin thread in the state that sewing is not performed, remove the needle thread from the thread path of thread take-up and remove the bobbin from the hook.
3. There is the possibility that the thread pulled out from the thread stand is loosened due to the influence (direction) of the wind and may be entangled in the handwheel. Be careful of the direction of the wind.

7. Adjusting the height of the knee lifter



WARNING :

Be sure to turn the power OFF before the following work in order to prevent personal injury due to unintentional starting of the sewing machine.

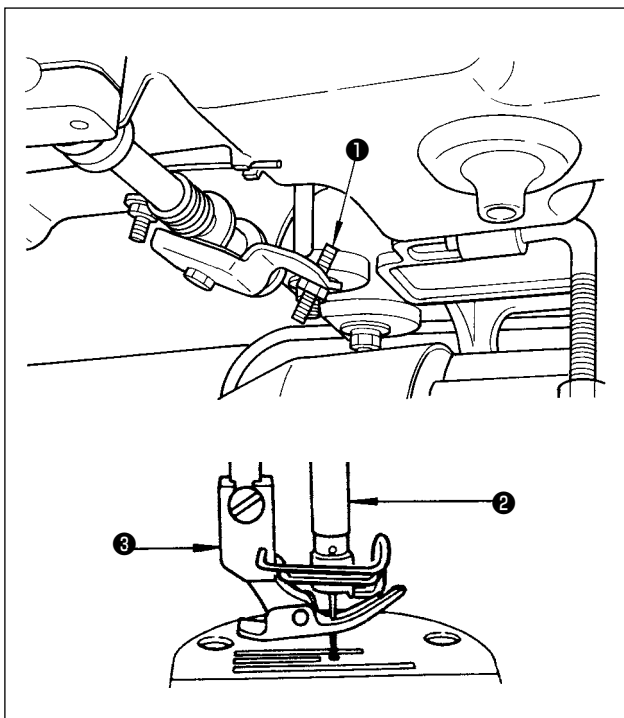

- 1) The standard height of the presser foot lifted using the knee lifter is 10 mm.
- 2) You can adjust the presser foot lift up to 13 mm using knee lifter adjust screw ①.
- 3) When you have adjusted the presser foot lift to over 10 mm, be sure that the bottom end of needle bar ② in its lowest position does not hit presser foot ③.

8. Installing the thread stand

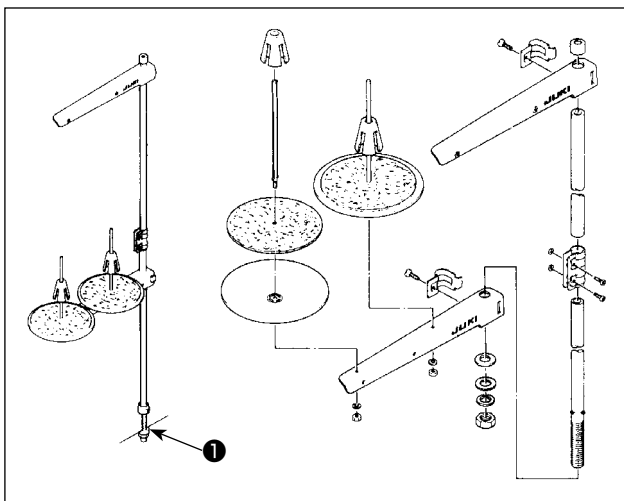

- 1) Assemble the thread stand unit, and insert it in the hole in the machine table.
- 2) Tighten nut ①.

9. Lubrication



WARNING :

1. Do not connect the power plug until the lubrication has been completed so as to prevent accidents due to abrupt start of the sewing machine,
2. To prevent the occurrence of an inflammation or rash, immediately wash the related portions if oil adheres to your eyes or other parts of your body.
3. If oil is mistakenly swallowed, diarrhea or vomiting may occur. Put oil in a place where children cannot reach.

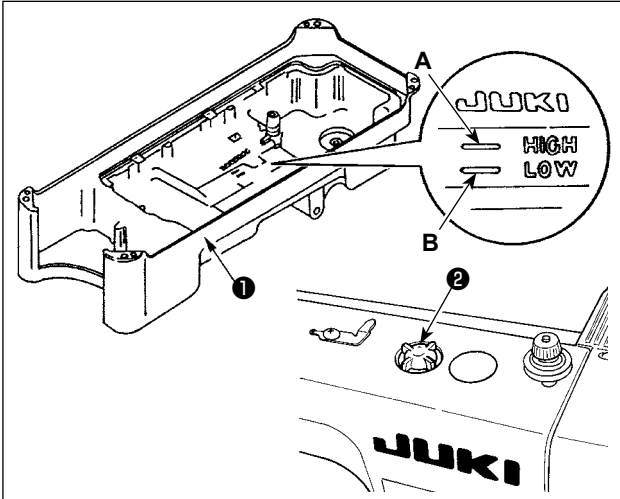

- 1) Before starting the sewing machine, fill oil pan ① with JUKI MACHINE OIL #7 up to "HIGH" mark A.
- 2) Add oil before the oil surface comes down to reach the "LOW" mark B.
- 3) When you operate the machine after lubrication, you will see splashing oil through oil sight window ② if the lubrication is adequate.
- 4) Note that the amount of the splashing oil is unrelated to the amount of the lubricating oil.



1. When you use a new sewing machine or a sewing machine after an extended period of dis-use, use the sewing machine after performing break-in at 2,000 sti/min or less.
2. For the oil lubrication, purchase JUKI NEW DEFRIX OIL No. 1 (Part No. : MDFRX1600C0) or JUKI MACHINE OIL #7 (Part No. : MML007600CA).
3. Be sure to lubricate clean oil.
4. When the oil surface is lower than the LOW mark, the oiling may be inconsistent. To prevent inconsistent oiling, add oil before the oil surface comes down to reach the LOW mark.

10. Adjusting the amount of oil (oil splashes)



WARNING :

Be extremely careful about the operation of the machine since the amount of oil has to be checked by turning the hook at a high speed.

(1) Confirmation of the amount of oil in the hook

① Amount of oil (oil splashes) confirmation paper

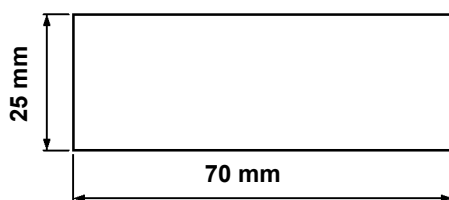

Oil splashes confirmation paper

② Position to confirm the amount of oil (oil splashes)

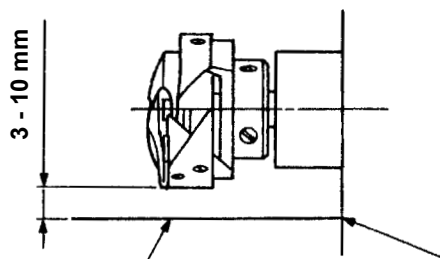

Closely fit the paper against the wall surface of the bed.

* When carrying out the procedure described below in 2), remove the slide plate and take extreme caution not to allow your fingers to come in contact with the hook.

- 1) If the machine has not been sufficiently warmed up for operation, make the machine run idle for approximately three minutes. (Moderate intermittent operation)
- 2) Place the amount of oil (oil spots) confirmation paper under the hook immediately after the machine stops running.
- 3) Confirm the height of the oil surface in the oil reservoir is within the range between "HIGH" and "LOW".
- 4) Confirmation of the amount of oil should be completed in five seconds. (Check the period of time with a watch.)

(2) Adjusting the amount of oil (oil spots) in the hook

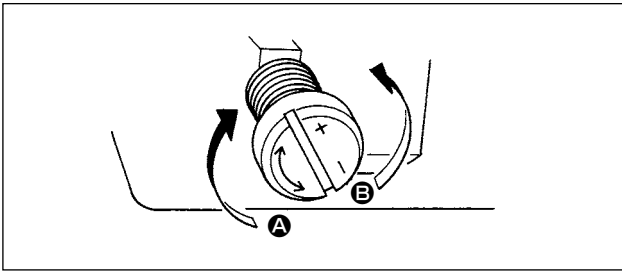

- 1) Turning the oil amount adjustment screw attached on the hook driving shaft front bushing in the “+” direction (in direction **A**) will increase the amount of oil (oil spots) in the hook, or in the “-” direction (in direction **B**) will decrease it.
- 2) After the amount of oil in the hook has been properly adjusted with the oil amount adjustment screw, make the sewing machine run idle for approximately 30 seconds to check the amount of oil in the hook.

(3) Sample showing the appropriate amount of oil in the hook

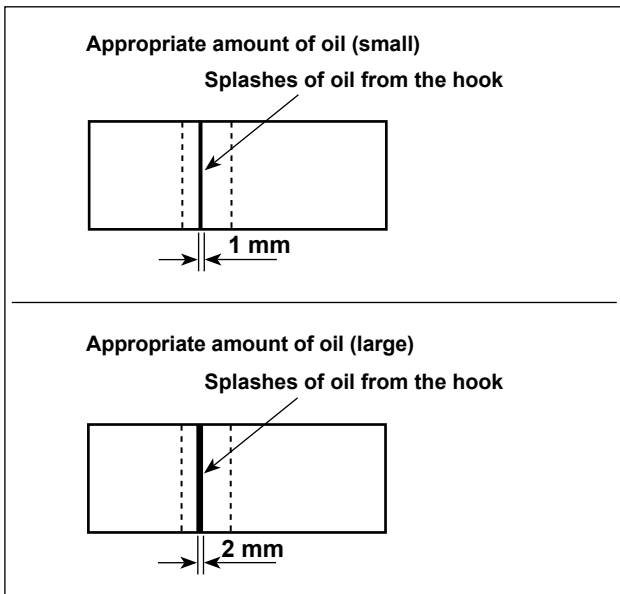

- 1) The amount of oil shown in the samples on the left should be finely adjusted in accordance with sewing processes. Be careful not to excessively increase/decrease the amount of oil in the hook. (If the amount of oil is too small, the hook will be seized (the hook will be hot). If the amount of oil is too much, the sewing product may be stained with oil.)
- 2) Check the oil amount (oil splashes) three times (with three sheets of paper).

(4) Confirmation of the amount of oil supplied to the face plate parts

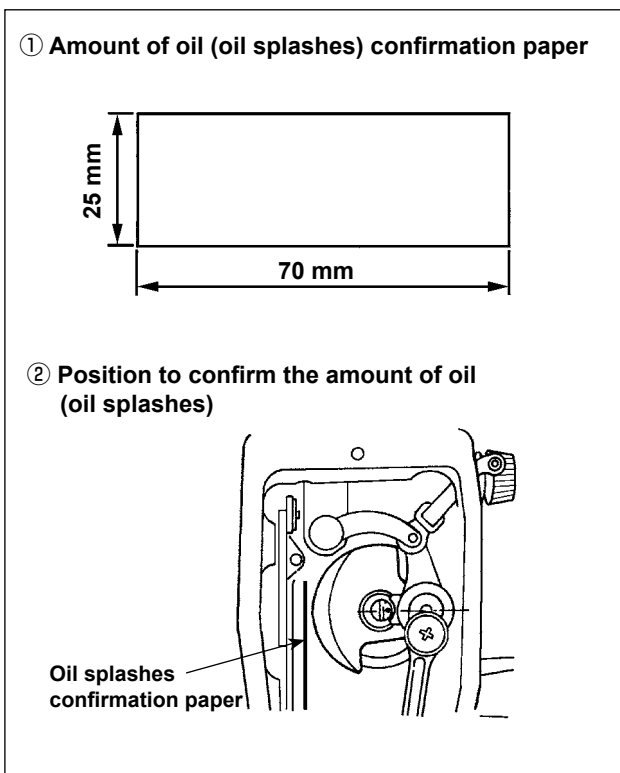

- * When carrying out the work described below in 2), remove the face plate and take extreme caution not to allow your fingers to come in contact with the thread take-up lever.
- 1) If the machine has not been sufficiently warmed up for operation, make the machine run idle for approximately three minutes. (Moderate intermittent operation)
 - 2) Place the amount of oil (oil spots) confirmation paper under the hook immediately after the machine stops running.
 - 3) Confirm the height of the oil surface in the oil reservoir is within the range between “HIGH” and “LOW”.
 - 4) The time required for the confirmation of the amount of oil (oil splashes) should be completed in ten seconds. (Measure the period of time with a watch.)

(5) Adjusting the amount of oil supplied to the face plate parts

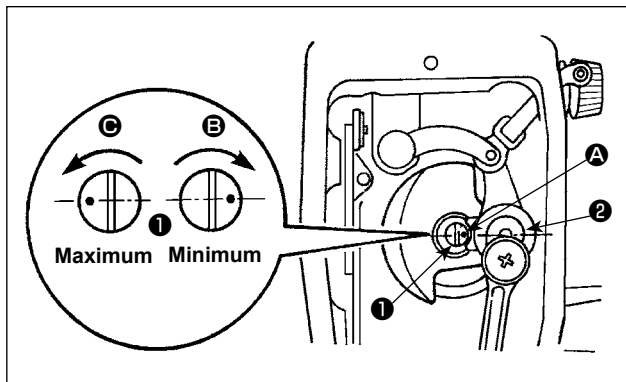

- 1) Adjust the amount of oil supplied to the thread take-up and needle bar crank ② by turning adjust pin ①.
- 2) The minimum amount of oil is reached when marker dot ① is brought close to needle bar crank ② by turning the adjust pin in direction ③.
- 3) The maximum amount of oil is reached when marker dot ① is brought to the position just opposite from the needle bar crank by turning the adjust pin in direction ④.

(6) Sample showing the appropriate amount of oil supplied to the face plate parts

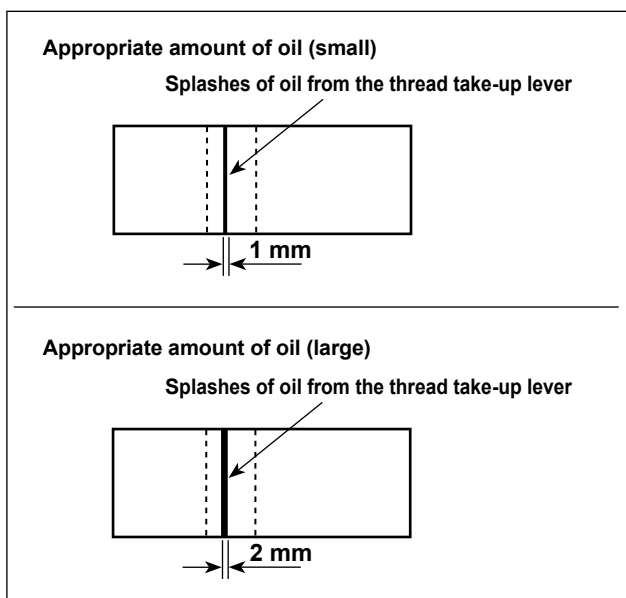

- 1) The state given in the figure shows the appropriate amount of oil (oil splashes). It is necessary to finely adjust the amount of oil in accordance with the sewing processes. However, do not excessively increase/decrease the amount of oil in the hook. (If the amount of oil is too small, the face plate parts will be hot or seize. If the amount of oil is too much, the sewing product may be stained with oil.)
- 2) Check the oil amount (oil splashes) three times (with three sheets of paper).

11. Attaching the needle



WARNING :

Be sure to turn the power OFF before the following work in order to prevent personal injury due to unintentional starting of the sewing machine.

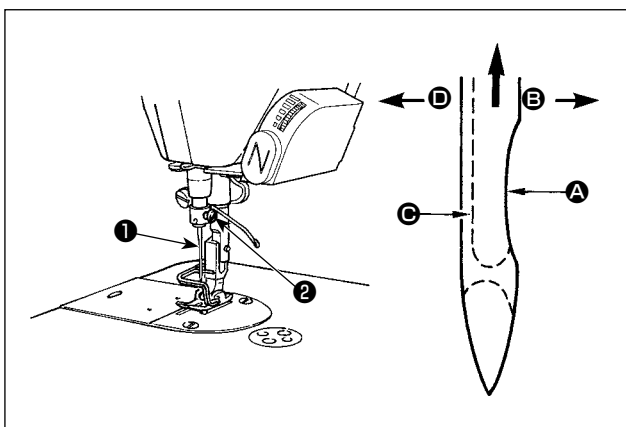

Use the specified needle for the machine. Use the proper needle in accordance with the thickness of thread used and the kinds of the materials.

- 1) Turn the handwheel until the needle bar reaches the highest point of its stroke.
- 2) Loosen screw ②, and hold needle ① with its indented part ① facing exactly to the right in direction ③.
- 3) Insert the needle fully into the hole in the needle bar in the direction of the arrow until the end of hole is reached.
- 4) Securely tighten screw ②.
- 5) Check that long groove ④ of the needle is facing exactly to the left in direction ④.



When polyester filament thread is used, if the indented part of the needle is tilted toward operator's side, the loop of thread becomes unstable. As a result, hangnail of thread or thread breakage may occur. For the thread that such phenomenon is likely to occur, it is effective to attach the needle with its indented part slightly slanting on the rear side.

12. Setting the bobbin into the bobbin case

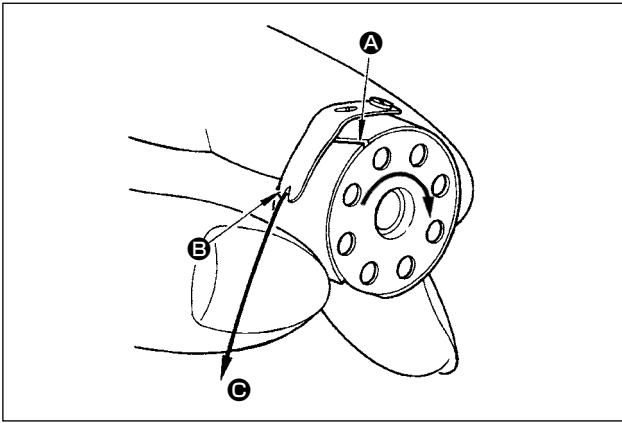

- 1) Pass the thread through thread slit **A**, and pull the thread in direction **C**. By so doing, the thread will pass under the tension spring and come out from notch **B**.
- 2) Check that the bobbin rotates in the direction of the arrow when thread is pulled.

13. Adjusting the stitch length

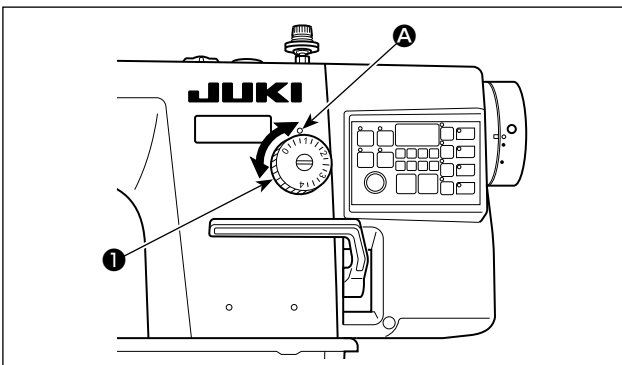

* The dial calibration is in millimeters (reference value).

- 1) Turn stitch length dial **1** in the direction of the arrow, and align the desired number to marker dot **A** on the machine arm.

14. Presser foot pressure

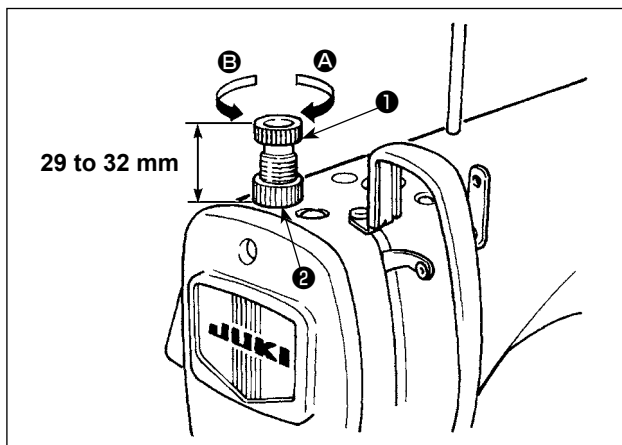

- 1) Loosen nut **2**. As you turn presser spring regulator **1** clockwise (in direction **A**), the presser foot pressure will be increased.
- 2) As you turn the presser spring regulator **1** counter-clockwise (in direction **B**), the pressure will be decreased.
- 3) After adjustment, tighten nut **2**.

The standard value of the pressure regulating thumb screw is 29 to 32 mm.

15. Hand lifter

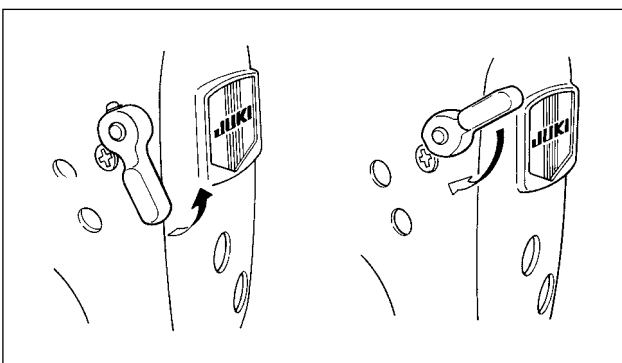

- 1) The presser foot is lifted by moving the lever upward.
- 2) The presser foot is lowered by moving the lever downward.

16. Adjusting the height of the presser bar



WARNING :

Be sure to turn the power OFF before the following work in order to prevent personal injury due to unintentional starting of the sewing machine.

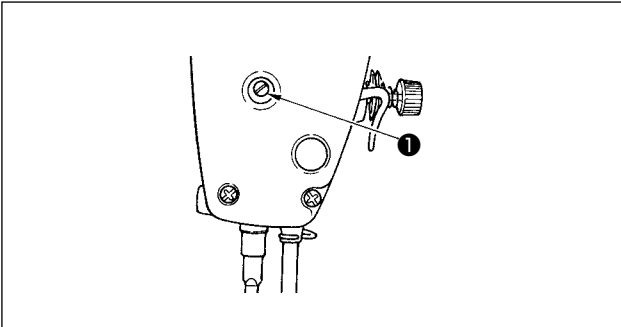

- 1) Loosen setscrew ❶, and adjust the presser bar height or the angle of the presser foot.
- 2) After adjustment, securely tighten the setscrew ❶.

17. Threading the machine head



WARNING :

Be sure to turn the power OFF before the following work in order to prevent personal injury due to unintentional starting of the sewing machine.

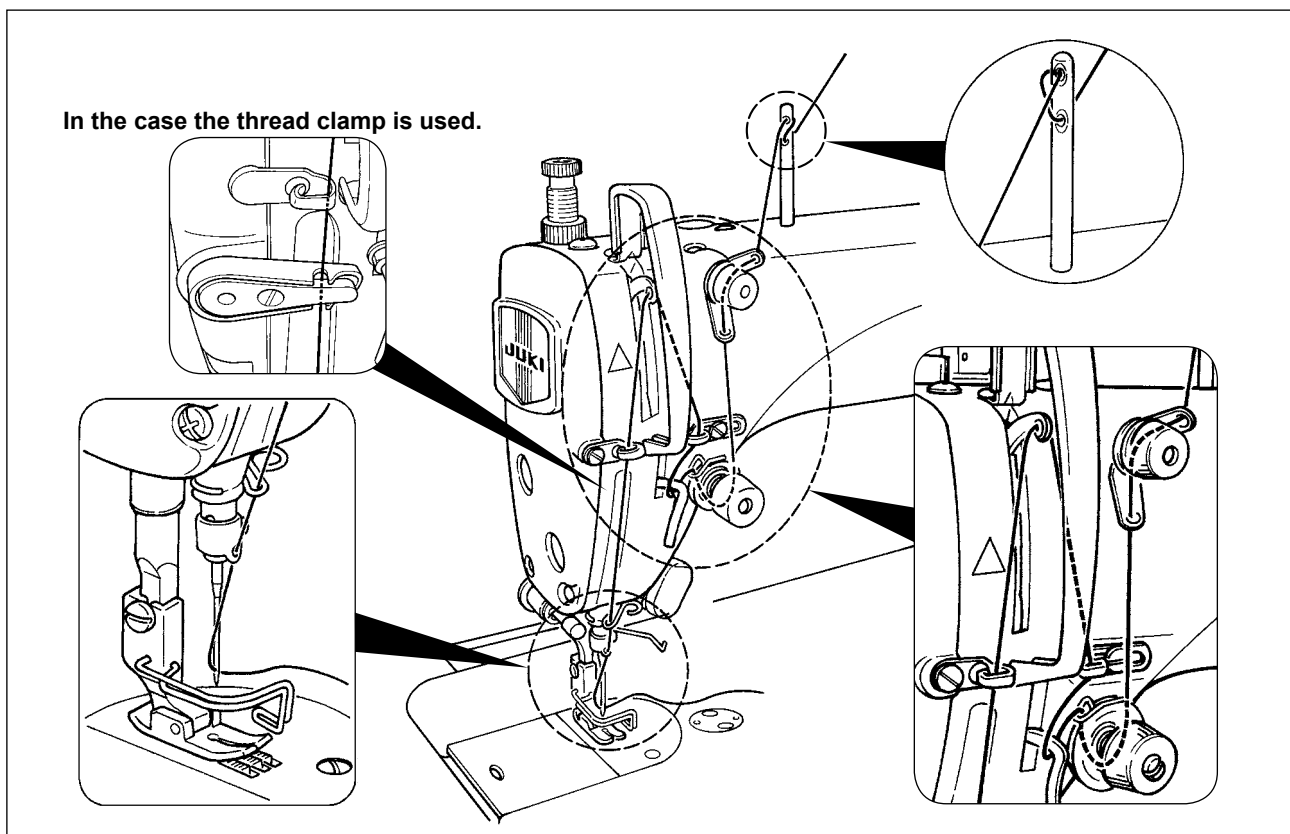

18. Thread tension

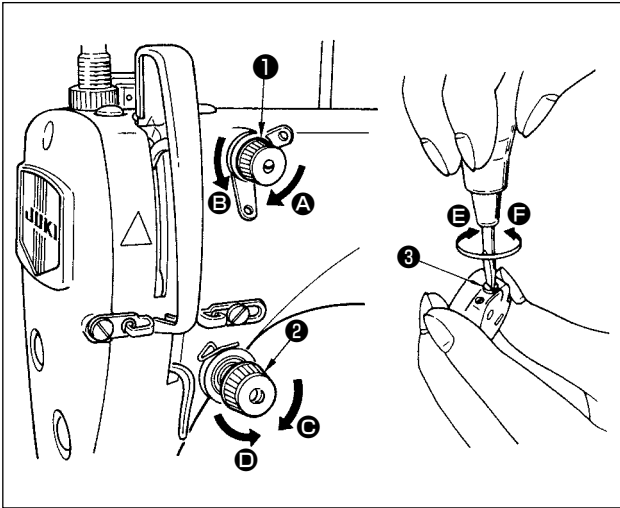

(1) Adjusting the needle thread tension

- 1) The length of thread remaining at the needle tip after thread trimming is shortened by turning tension regulating nut No. 1 **1** clockwise in direction **A**.
- 2) It is lengthened by turning the nut counterclockwise in direction **B**.
- 3) The needle thread tension is increased by turning tension regulating nut No. 2 **2** clockwise in direction **C**.
- 4) It is decreased by turning the nut counterclockwise in direction **D**.

(2) Adjusting the bobbin thread tension

- 1) The bobbin thread tension is increased by turning tension regulating screw **3** clockwise in direction **E**.
- 2) It is decreased by turning the screw counterclockwise in direction **F**.

19. Thread take-up spring

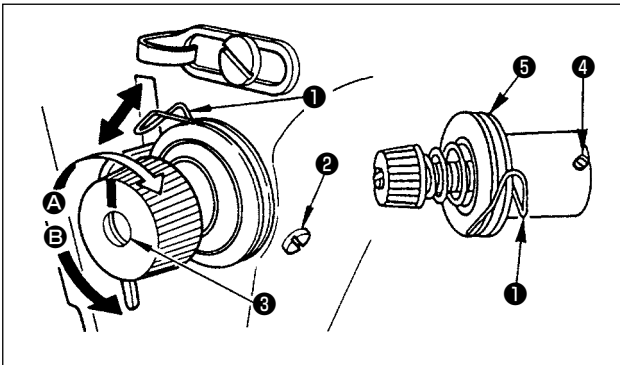

(1) Changing the stroke of thread take-up spring **1**

- 1) Loosen setscrew **2**.
- 2) As you turn tension post **3** clockwise (in direction **A**), the stroke of the thread take-up spring will be increased.
- 3) As you turn tension post **3** counterclockwise (in direction **B**), the stroke will be decreased.

(2) Changing the pressure of thread take-up spring **1**

- 1) Loosen setscrew **2**, and remove thread tension asm. **5**.
- 2) Loosen setscrew **4**.
- 3) As you turn tension post **3** clockwise (in direction **A**), the pressure will be increased.
- 4) As you turn the tension post counterclockwise (in direction **B**), the pressure will be decreased.

20. Adjusting the thread take-up stroke



WARNING :

Be sure to turn the power OFF before the following work in order to prevent personal injury due to unintentional starting of the sewing machine.

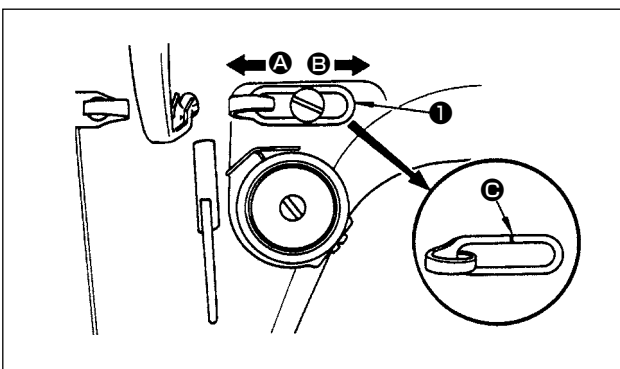

- 1) When sewing heavy-weight materials, move thread guide **1** to the left (in direction **A**) to increase the length of thread pulled out by the thread take-up.
- 2) When sewing light-weight materials, move thread guide **1** to the right (in direction **B**) to decrease the length of thread pulled out by the thread take-up.
- 3) Normally, thread guide **1** is positioned in a way that marker line **C** is aligned with the center of the screw.

21. Needle-to-hook relationship



WARNING :

Be sure to turn the power OFF before the following work in order to prevent personal injury due to unintentional starting of the sewing machine.

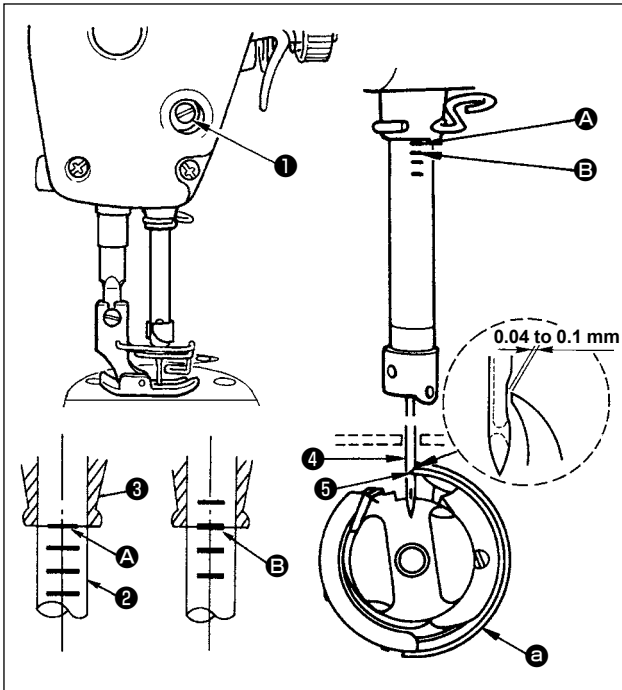

Adjust the timing between the needle and the hook as follows :

- 1) Turn the handwheel to bring the needle bar down to the lowest point of its stroke, and loosen setscrew ①.

Adjusting the needle bar height.

- 2) Align marker line ① on needle bar ② with the bottom end of needle bar lower bushing ③, then tighten setscrew ①.

Adjusting position of the hook ④.

- 3) Loosen the three hook setscrews, turn the handwheel and align marker line ① on ascending needle bar ② with the bottom end of needle bar lower bushing ③.
- 4) After making the adjustments mentioned in the above steps, align hook blade point ⑤ with the center of needle ④. Provide a clearance of 0.04 mm to 0.1 mm (reference value) between the needle and the hook, then securely tighten setscrews in the hook.



If the clearance between the blade point of hook and the needle is smaller than the specified value, the blade point of hook will be damaged. If the clearance is larger, stitch skipping will result.

22. Height of the feed dog



WARNING :

Be sure to turn the power OFF before the following work in order to prevent personal injury due to unintentional starting of the sewing machine.

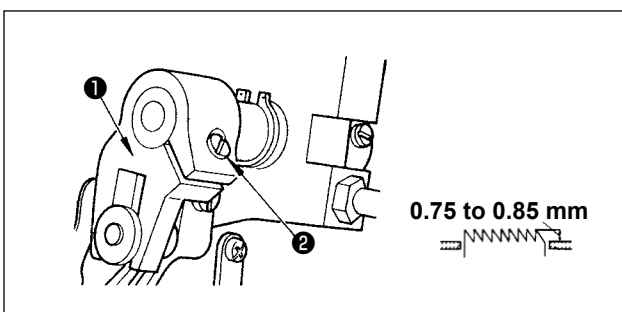

To adjust the height of the feed dog :

- 1) Loosen screw ② of crank ①.
- 2) Move the feed bar up or down to make adjustment.
- 3) Securely tighten screw ②.



If the clamping pressure is insufficient, the motion of the forked portion becomes heavy.

23. Tilt of the feed dog



WARNING :

Be sure to turn the power OFF before the following work in order to prevent personal injury due to unintentional starting of the sewing machine.

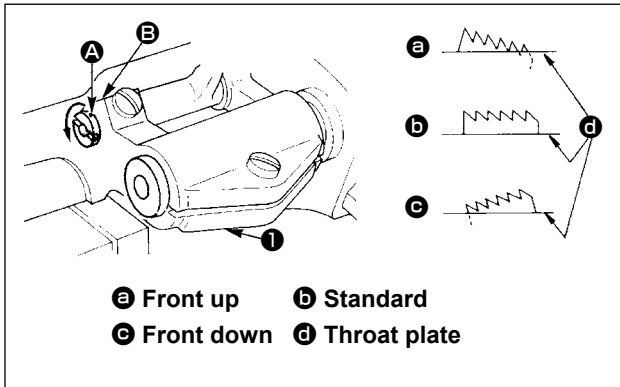

- 1) The standard tilt (horizontal) of the feed dog is obtained when marker dot **A** on the feed bar shaft is aligned with marker dot **B** on feed rocker **1**.
- 2) To tilt the feed dog with its front up in order to prevent puckering, loosen the setscrew, and turn the feed bar shaft 90° in the direction of the arrow, using a screwdriver.
- 3) To tilt the feed dog with its front down in order to prevent uneven material feed, turn the feed bar shaft 90° in the opposite direction from the arrow.



Whenever the feed dog tilt is adjusted, the feed dog height will be changed. So, it is necessary to check the height after tilt adjustment.

24. Adjusting the feed timing



WARNING :

Be sure to turn the power OFF before the following work in order to prevent personal injury due to unintentional starting of the sewing machine.

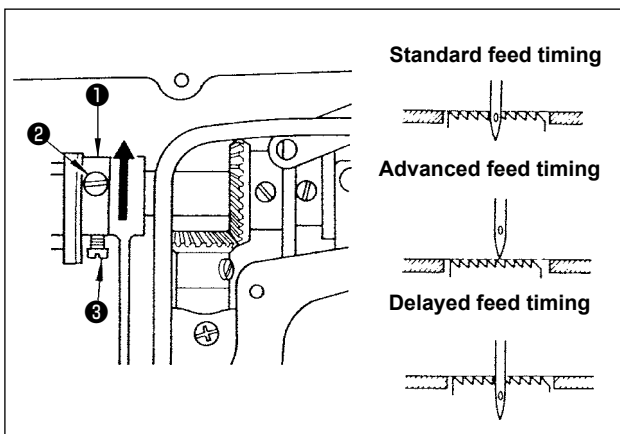

- 1) Loosen screws **2** and **3** in feed eccentric cam **1**, move the feed eccentric cam in the direction of the arrow or opposite direction of the arrow, and firmly tighten the screws.
- 2) For the standard adjustment, adjust so that the top surface of feed dog and the top end of needle eyelet are flush with the top surface of throat plate when the feed dog descends below the throat plate.
- 3) To advance the feed timing in order to prevent uneven material feed, move the feed eccentric cam in the direction of the arrow.
- 4) To delay the feed timing in order to increase stitch tightness, move the feed eccentric cam in the opposite direction from the arrow.



Be careful not to move the feed eccentric cam too far, or else needle breakage may result.

25. Counter knife



WARNING :

Be sure to turn the power OFF before the following work in order to prevent personal injury due to unintentional starting of the sewing machine.



When sharpening again the counter knife ①, extra special care must be taken on the handling of the knife.

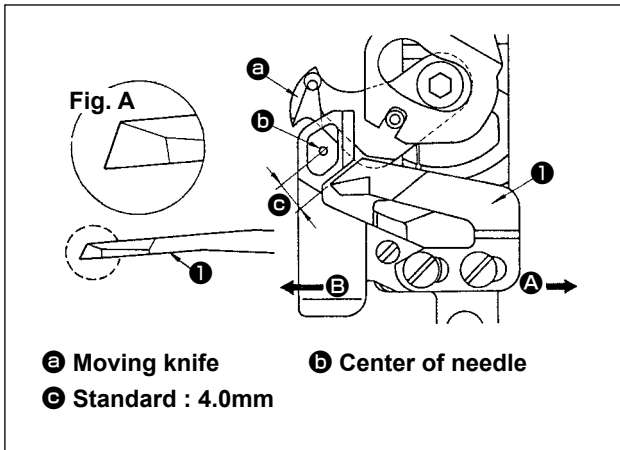

If the knife does not cut thread sharply, immediately re-sharpen counter knife ① as illustrated in Fig. A and re-install it properly.

- 1) If the mounting position of the counter knife is moved in direction **A** from the standard mounting position, the thread length after thread trimming will be increased accordingly.
- 2) If the mounting position is moved in direction **B**, the thread length will be decreased accordingly.

26. Pedal pressure and pedal stroke



WARNING :

Be sure to turn the power OFF before the following work in order to prevent personal injury due to unintentional starting of the sewing machine.

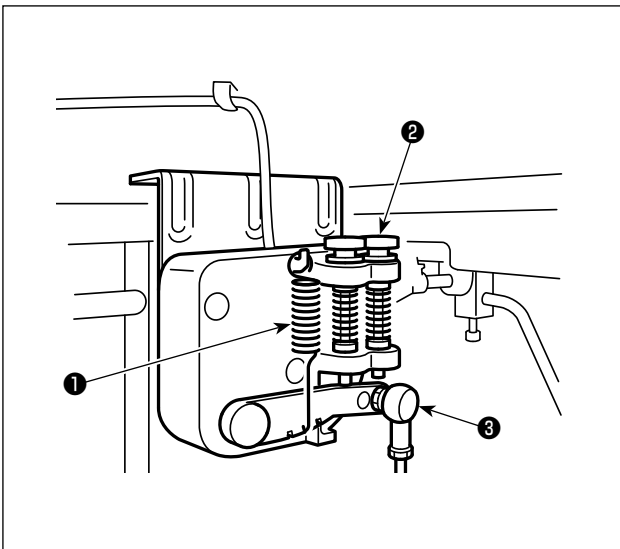

(1) Adjusting the pressure required to depress the front part of the pedal

- 1) This pressure can be changed by changing the mounting position of pedaling pressure adjust spring ①.
- 2) The pressure decreases when you hook the spring on the left side.
- 3) The pressure increases when you hook the spring on the right side.

(2) Adjusting the pressure required to depress the back part of the pedal

- 1) This pressure can be adjusted using regulator screw ②.
- 2) The pressure increases as you turn the regulator screw in.
- 3) The pressure decreases as you turn the screw out.

(3) Adjusting the pedal stroke

- 1) The pedal stroke increases when you insert connecting rod ③ into the right hole.

27. Adjustment of the pedal



WARNING :

Be sure to turn the power OFF before the following work in order to prevent personal injury due to unintentional starting of the sewing machine.

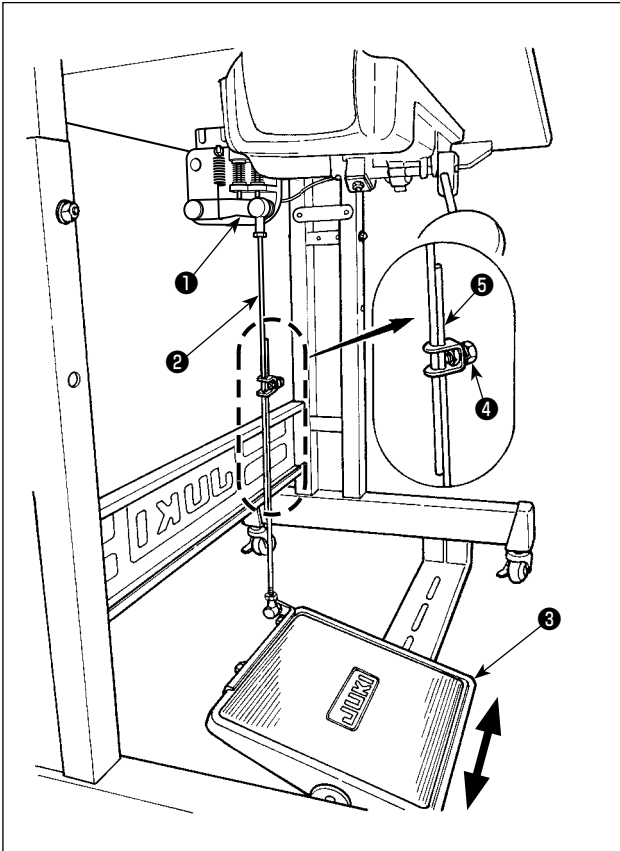

(1) Installing the connecting rod

- 1) Move pedal **3** to the right or left as illustrated by the arrows so that motor control lever **1** and connecting rod **2** are straightened.

(2) Adjusting the pedal angle

- 1) The pedal tilt can be freely adjusted by changing the length of the connecting rod **2**.
- 2) Loosen adjust screw **4**, and adjust the length of connecting rod **5**.

28. Marker dots on the handwheel

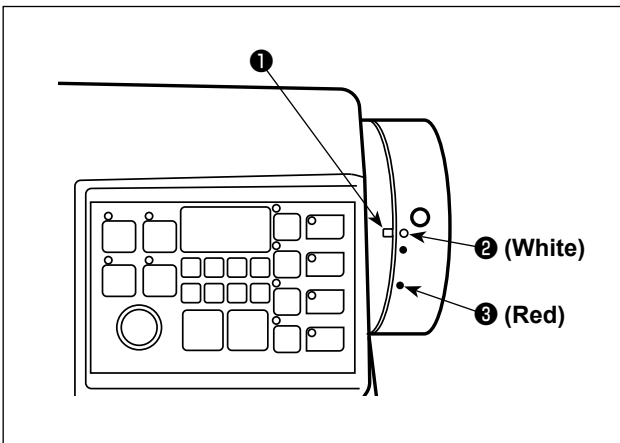

The upper stop position of the needle bar is reached when marker dot **1** on the cover is aligned with white marker dot **2** on the handwheel.

The operating timing of the thread trimming cam is when marker dot **1** on the cover is aligned with red marker dot **3** on the handwheel.

III. FOR THE OPERATOR

1. Operating procedure of the sewing machine

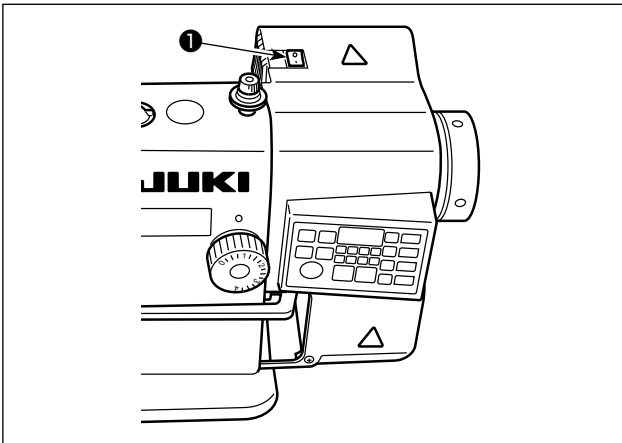

- 1) Press the power switch **1** to turn the power ON. The power switch **1** is in the ON state when the "I" mark side is pressed. It is in the OFF state when the "O" side is pressed.



If the power indicator LED on the panel does not light up after having turned ON the power switch **1, immediately turn OFF the power switch **1** and check the supply voltage.**

In addition, in such a case as this, re-turn ON the power switch **1 when 2 to 3 minutes or more have passed after turning OFF the power switch.**

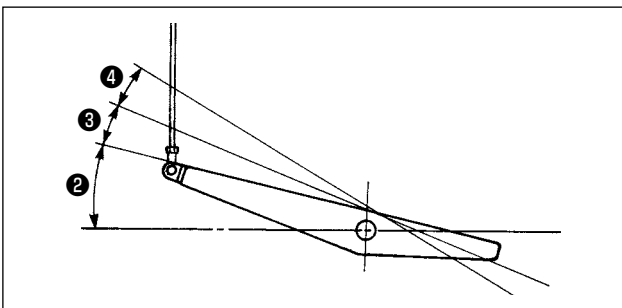

- 2) When the power switch **1** is turned ON, the sewing machine automatically turns to bring the needle bar to its UP position in the case the needle bar is not in that position.



When turning ON the power, the needle bar moves. Do not put your hands or things under the needle.

- a. The machine runs at low sewing speed when you lightly depress the front part of the pedal. **2**
- b. The machine runs at high sewing speed when you further depress the front part of the pedal. **2**
(If the automatic reverse feed stitching has been preset, the machine runs at high speed after it completes reverse feed stitching.)

c. The machine stops (with its needle up or down) when you reset the pedal to its original position.

d. The machine trims threads when you fully depress the back part of the pedal. **4**

* When the auto-lifer (AK device) is used, one more operating switch is provided between the sewing machine stop switch and thread trimming switch. The presser foot goes up when you lightly depress the back part of the pedal **3**, and if you further depress the back part **4**, the thread trimmer is actuated.

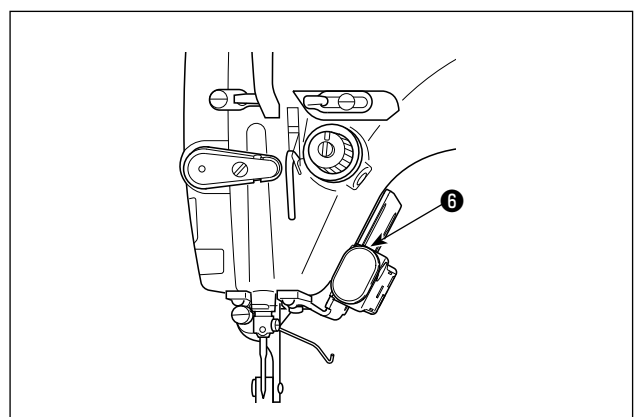
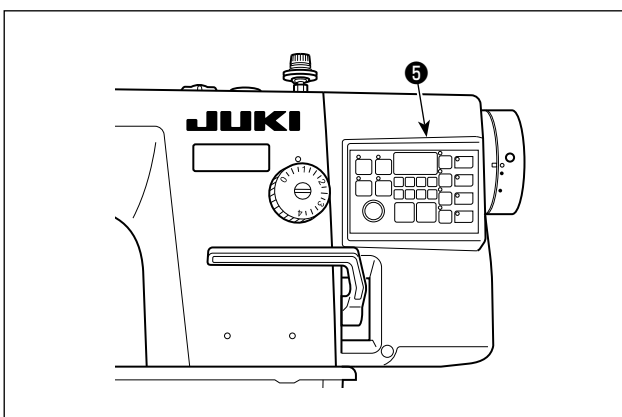

- 4) Reverse feed stitching at the beginning of sewing, reverse feed stitching at the end of sewing and various sewing patterns can be set on built-in panel **5** of the machine head.

- 5) When one-touch type reverse feed switch **6** is pressed, the sewing machine performs reverse feed stitching.

- 6) When you have finished sewing, confirm first that the sewing machine has stopped. Then, press the power switch **1** to turn the power OFF.





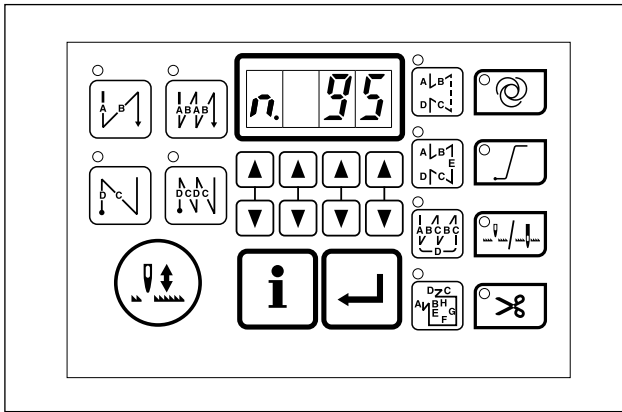

In the case the machine is not used for a long time, remove the power plug from the plug receptacle.

2. Setting procedure of the machine head

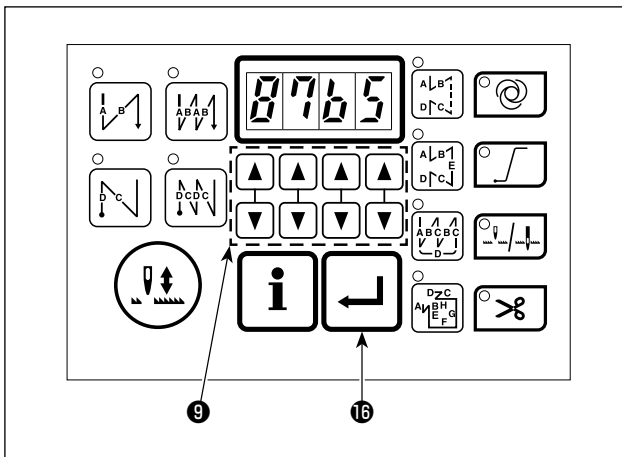



- 1) Refer to **"III-6. Setting of functions" p.24** and call the function setting No. 95.

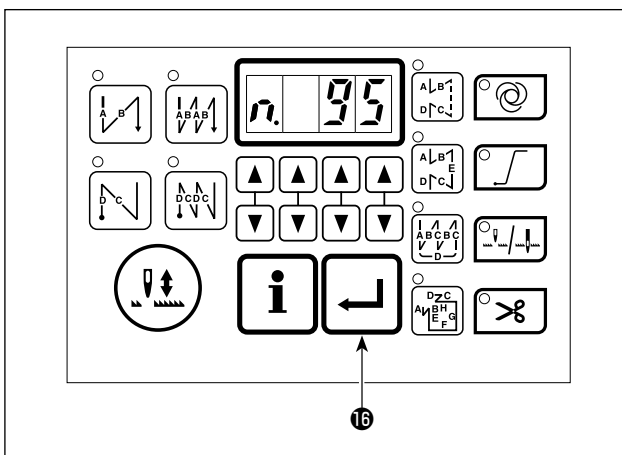

- 2) Press  switch **16**.
- 3) Press  and  switches **9** to select the type of the machine head.

87bS	Light- to Medium-weight materials
87bH	Heavy-weight materials



- 4) After the selection of the type of the machine head, press  switch **16** to confirm the selection. The settings are automatically initialized according to the type of the machine head.

3. Operation panel built in the machine head

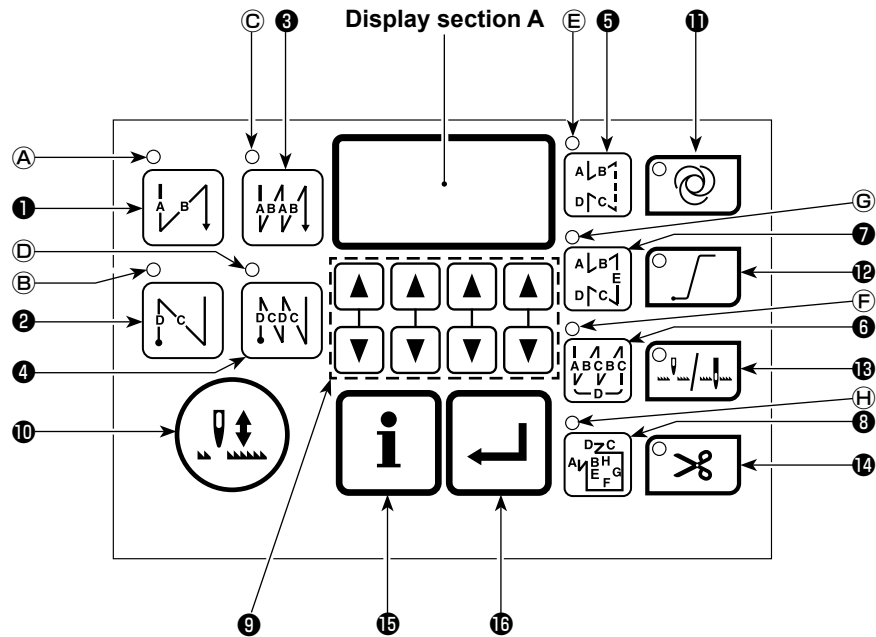

①		Used to change over the automatic reverse feed stitching at the beginning of sewing between enable and disable.	⑨		Used to change the contents displayed on the display section.
②		Used to change over the automatic reverse feed stitching at the end of sewing between enable and disable.	⑩		Used to carry out compensating stitching in half-stitch steps.
③		Used to change over the automatic double reverse feed stitching at the beginning of sewing between enable and disable.	⑪		Used to change over the one-shot automatic stitching between enable and disable.
④		Used to change over the automatic double reverse feed stitching at the end of sewing between enable and disable.	⑫		Used to change over the soft-start function between enable and disable.
⑤		Used to change over the reverse feed stitching pattern between enable and disable.	⑬		Used to change over the needle bar stop position at the time of stopping sewing between up and down.
⑥		Used to change over the overlapped stitching pattern between enable and disable.	⑭		Used to change over the thread trimming operation between enable and disable.
⑦		Used to change over the constant-dimension stitching pattern between enable and disable.	⑮		Used to change over the operation mode to the function setting mode.
⑧		Used to change over the overlapped stitching pattern between enable and disable.	⑯		Used to confirm the settings changed under the function setting mode.

4. Operating procedure of the sewing pattern

Caution Refer to the Instruction Manual for each operation panel for how to operate sewing patterns using other operation panel than the built-in panel of the machine head.

(1) Reverse feed stitching pattern

Reverse feed stitching at sewing start and reverse feed stitching at sewing end can be separately programmed.

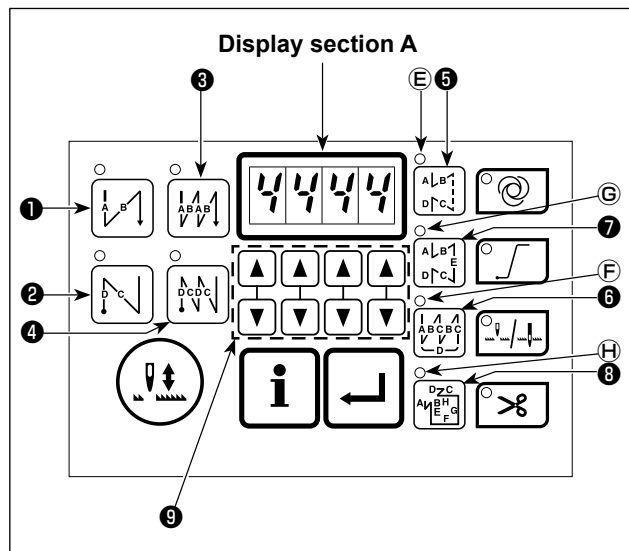

[Setting procedure of the reverse feed stitching]

1) Effective/ineffective of the reverse feed stitching

pattern can be changed over by pressing switch **5**.

When the reverse feed stitching pattern is enabled, LED **E** lights up and the display section **A** shows the number of reverse feed stitches at the beginning of sewing and that at the end of sewing.

Use and switches **9** to change the number of stitches for the target process (A, B, C or D). (The number of stitches that can be set is 0 to 15.)

The numbers of stitches for processes A, B, C and D are displayed on display section **A** from left to right in the order from A to D.

2) Enable/disable of the reverse feed stitching at the beginning of sewing is set by pressing switch **1**.

Enable/disable of the reverse feed stitching at the end of sewing is set by pressing switch **2**.

Enable/disable of the double reverse feed stitching at the beginning of sewing is set by pressing switch **3**.

Enable/disable of the double reverse feed stitching at the end of sewing is set by pressing switch **4**.

Caution The number which exceeds 9 is indicated as follows:
A = 10, b = 11, c = 12, d = 13, E = 14, and F = 15.

(2) Overlapped stitching pattern

Overlapped stitching pattern can be programmed.

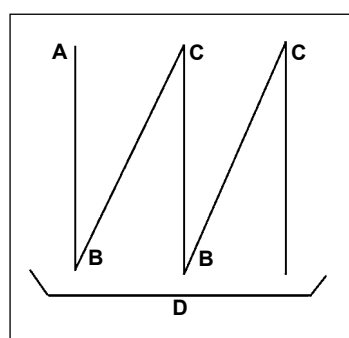

A : Number of stitches of normal stitching setting : 0 to 15 stitches

B : Number of stitches of reverse stitching setting : 0 to 15 stitches

C : Number of stitches of normal stitching setting : 0 to 15 stitches

D : Number of times of repetition : 0 to 15 times

1. When process D is set to 5 times, the sewing is repeated as

A → B → C → B → C.

2. The number which exceeds 9 is indicated as follows:

A = 10, b = 11, c = 12, d = 13, E = 14, and F = 15.

[Setting procedure of the overlapped stitching]

1) Effective/ineffective of the overlapped stitching pattern can be changed over by pressing switch **6**.
When the overlapped stitching pattern is rendered effective, LED **F** lights up.





2) Press and switches **9** to change the number of stitches for target process (A, B, C or D).

(3) Constant-dimension stitching pattern





The constant-dimension stitching pattern can be set.

[How to set the constant-dimension stitching]

• Straight stitching

- 1) Press  switch **7** to select the constant-dimension sewing pattern.
When the constant-dimension stitching pattern is enabled, LED **6** lights up.
- 2) When the constant-dimension sewing pattern is selected, the number of stitches of process E can be set by pressing  switch **7** again.
- 3) The number of stitches (0 to 999) for the constant-dimension stitching can be selected by pressing  and  switches **9**.

• Label sewing

- 1) Press  switch **8** to select the label sewing.
When the selection is effective, LED **8** lights up.
Every time  switch **8** is pressed, the indication of processes E to H will be changed over.
- 2) Display the target process the number of stitches of which is to be changed. In this state, the number of stitches of the processes (EFGH) can be changed by pressing  and  switches **9**.

5. One-touch setting

A part of function setting items can be easily changed in the normal sewing state.

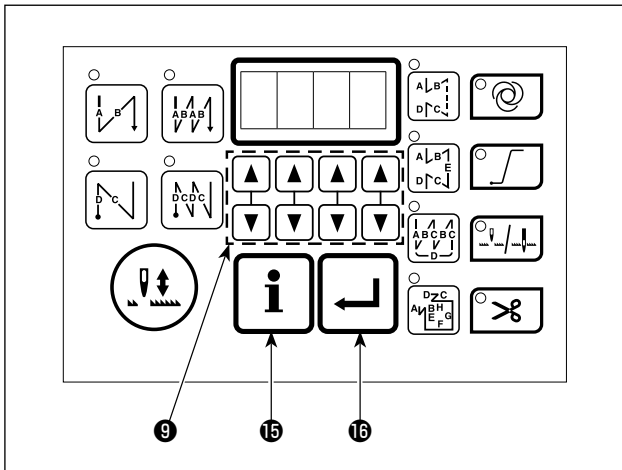

Keep **i** switch **15** held pressed (for two seconds or more) to carry out setting.

* If the indication shown on the screen does not change, keep the switch held pressed again.

[Setting items]

SPd (SPd)	Sewing speed
When function setting No. 20 is set at "0": nIP (nIP) When function setting No. 20 is set at "1": Wip (WIP)	Thread clamp (wiper) operation : ON/OFF
TrM (TrM)	Thread trimming operation after one-shot automatic stitching: ON/OFF
n. (n.)	Function setting

[Setting procedure (example: Wip)]

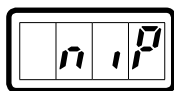

1) Press **▲** and **▼** switches **9** to select the setting item. (Example: niP)



2) Press **←** switch **16**. The current set value is displayed. (Example: on)



3) Press **▲** and **▼** switches **9** to change the set value. (Example: oFF)



4) Press **←** switch **16** to confirm the set value.

5) Press **i** switch **15** to finish the one-touch setting.



1. In the case the function setting (n.) is selected, operation using **i** switch **15** cannot be carried out. Once the setting of the function setting is finished, turn the power "ON", then "OFF" and "ON" again.
2. Once the power switch is turned off, be sure to wait for ten seconds or more before turning it on again. If the power is re-turned on immediately after it has been turned off, the sewing machine may not operate normally. In such a case, turn the power on again correctly.

6. Setting of functions

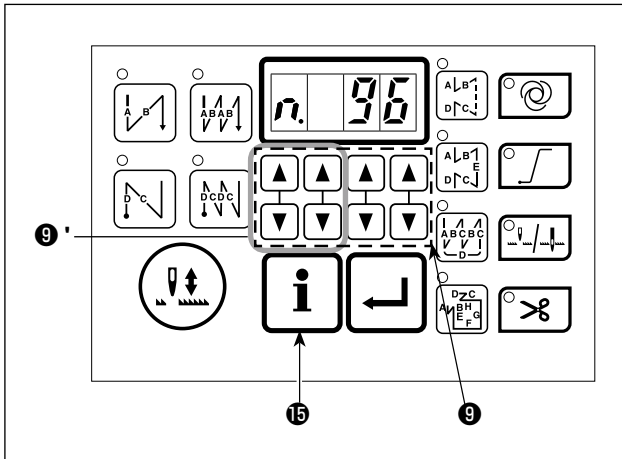

Set value for the function setting can be changed.



- 1) Turn the power ON while keeping  switch **15** held pressed.

The indication on the display section is changed to "n. ".

The numeric character displayed on the right side of "n." represents the function setting number. (The figure shows the case of "No. 96 Maximum sewing speed".)

- 2) Press  and  switches **9** to change the number of function setting.

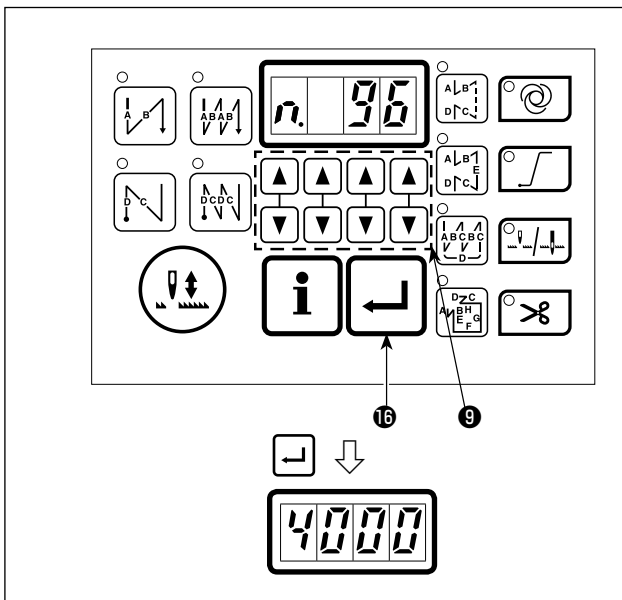

Important  and  switches **9** (two switches on the left) are used for changing the number in the "fast-feed" mode.



- 3) Press  switch **16** to change the setting.

The indication is changed to the set value.

(The figure shows the case where the set value is changed from the indication "n.96" to "4000" (set value) by pressing  switch **16**.)

- 4) Press  and  switches **9** to change the set value.

- 5) Press  switch **16** to confirm the set value.

- 6) The display returns to the state described in 1).

To additionally change the set value for other function setting numbers, repeat the steps of procedure from 2).

When you have completed the set value changing, press  switch **10**. The sewing machine is restored to its normal sewing state.

7. Production support function

The production support function enables "sewing counting", "bobbin-thread counting" and "number of stitches counting".

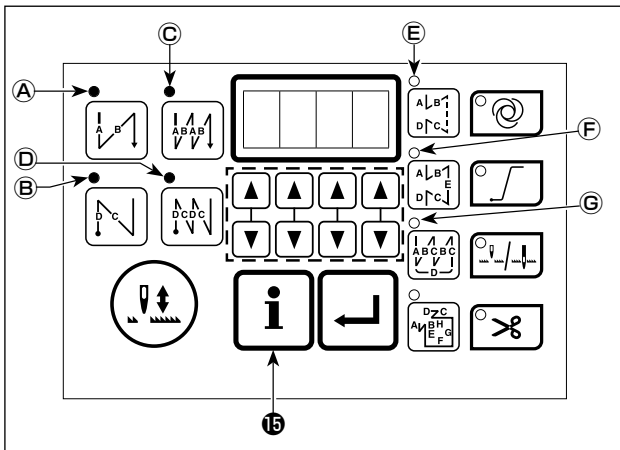

- 1) When **i** switch 15 is pressed while the sewing machine is in the sewing state, the product support function is invoked. At this time, LEDs (A), (B), (C) and (D) light up.
- 2) Every time **i** switch 15 is pressed, the function display will be changed over in the order of the "sewing counting function", the "bobbin-thread counting function", the "number of stitches counting function" and the "sewing state".

* Sewing counting function (LED (E) lights up)

The value indicated on the counter is increased every time the preset number of times of thread trimming is reached.

It is possible to prohibit the sewing machine from starting when the value indicated on the counter reaches the preset one, if desired.

* Bobbin thread counting function (LED (F) lights up)

The number of stitches sewn is detected. The preset value indicated on the counter is subtracted according to the detected number of stitches.

Once the value indicated on the counter becomes a negative value, the bobbin thread has to be replaced.

* Number of stitches counting function (LED (G) lights up)

The number of stitches is counted from the start of sewing until thread trimming is carried out.

[Sewing counting function]

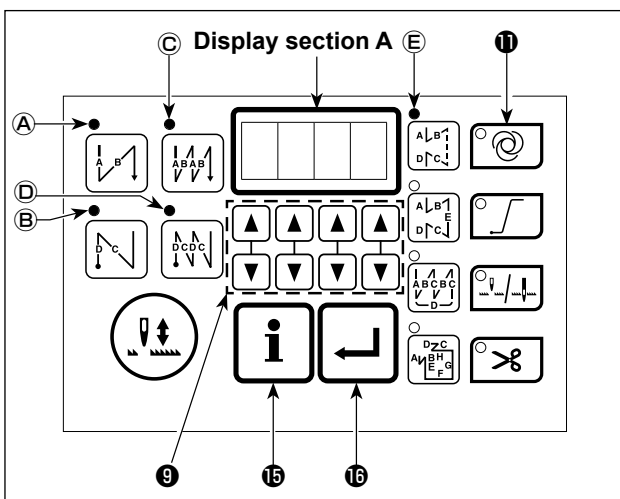

- 1) Counted value is indicated on display section A.
- 2) The value on the counter can be changed by pressing **▲** and **▼** switches 9.
- 3) The value on the counter is reset to 0 (zero) by pressing **⊙** switch 11.
- 4) The sewing counting function setting can be changed by keeping **i** switch 15 held pressed (for two seconds).
- 5) The function setting changing operation is finished by pressing **i** switch 15.

The setting items which can be changed are as follows:



- * No. 181..... Target number of products
- * No. 182..... Operation to be carried out when the target number of products is reached
 - 0 : No operation
 - 1 : Sewing machine operation is disabled

When the value on the counter equals to the target number of products, the sewing machine will not run even if the pedal is depressed. At this time, the display automatically changed to "sewing counter function". To release the sewing machine from the disabled state, the value on the counter is reset to 0 (zero) by pressing **⊙** switch 11.

- * No. 183..... The number of times of thread trimming to be carried out during one sewing sequence
 - The number of times of thread trimming for stopping the sewing counter is set.

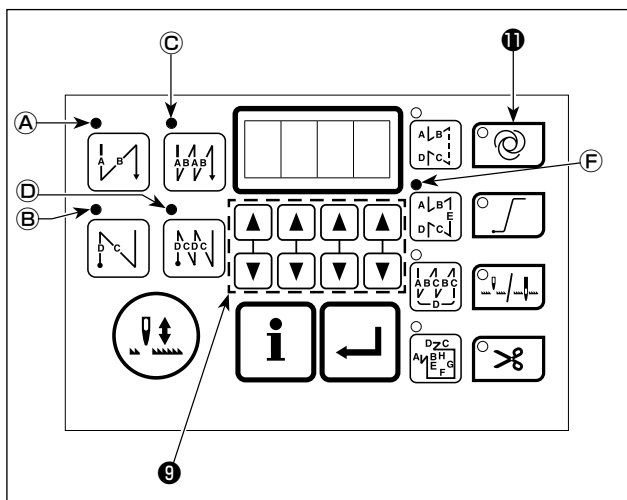
[Bobbin thread counting function]



- 1) Operate this function in the state where sewing is finished.
The value on the counter cannot be changed if thread trimming has not been carried out.
- 2) The value on the counter is reset to the initial value by pressing  switch 11.
- 3) In this state, the initial value can be changed by pressing  and  switches 9.

[Number of stitches counting function]

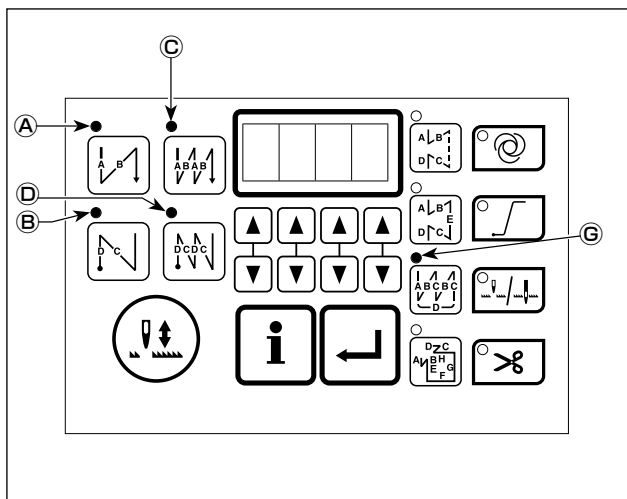

- 1) The number of stitches is automatically counted from the start of sewing until thread trimming is carried out.
- 2) Once thread trimming is carried out, the value on the counter is reset to 0 (zero).

8. Function setting list

No.	Item	Description	Setting range	Default	Ref. page
1	Soft start function	The number of stitches to be sewn at a low speed when the soft-start function is used at the start of sewing. (* This setting is enabled when the thread clamp function is in the OFF state.) 0 : The function is not selected. 1 to 9 : The number of stitches to be sewn under the soft-start mode.	0 to 9 (Stitches)	<input type="text" value=""/> <input type="text" value=""/> <input type="text" value=""/> <input type="text" value="3"/>	31
2	Material end sensor function	Material end sensor function. 0 : Material end detection function is not operative. 1 : After detecting material end, the specified number of stitches (No. 4) will be sewn, and the sewing machine will stop.	0/1	<input type="text" value=""/> <input type="text" value=""/> <input type="text" value=""/> <input type="text" value="0"/>	
3	Thread trimming function by material end sensor	Thread trimming function by material end sensor. 0 : Automatic thread trimming function after detection of material end is not operative. 1 : After detecting material end, the specified number of stitches (No. 4) will be sewn, and the sewing machine will stop and perform automatic thread trimming.	0/1	<input type="text" value=""/> <input type="text" value=""/> <input type="text" value=""/> <input type="text" value="0"/>	
4	Number of stitches for material end sensor	Number of stitches for material end sensor. Number of stitches from detection of material end to stop of the sewing machine.	0 to 19 (Stitches)	<input type="text" value=""/> <input type="text" value=""/> <input type="text" value=""/> <input type="text" value="5"/>	
5	Flicker reducing function	Flicker reducing function 0 : Flicker reducing function is not operative. 1 : Flicker reducing function is effective.	0/1	<input type="text" value=""/> <input type="text" value=""/> <input type="text" value=""/> <input type="text" value="0"/>	31
* 7	Unit of bobbin thread counting down	Unit of bobbin thread counting down 0 : 1 Count/10 stitches 1 : 1 Count/15 stitches 2 : 1 Count/20 stitches	0 to 2	<input type="text" value=""/> <input type="text" value=""/> <input type="text" value=""/> <input type="text" value="0"/>	
* 8	Sewing speed of reverse feed stitching	Sewing speed of reverse feed stitching is set.	150 to 3,000 (sti/min)	<input type="text" value="1"/> <input type="text" value="9"/> <input type="text" value="0"/> <input type="text" value="0"/>	
12	Optional switch function selection	Switching of function of optional switch.		<input type="text" value="o"/> <input type="text" value="P"/> <input type="text" value="T"/> <input type="text" value="_"/>	31
* 13	Function of prohibiting start of the sewing machine by bobbin thread counter	Function of prohibiting start of the sewing machine by bobbin thread counting 0 : When counting is out (-1 or less) Function of prohibiting start of the sewing machine is not operative. 1 : When counting is out (-1 or less) Function of prohibiting start of the sewing machine after thread trimming is operative. 2 : When counting is out (-1 or less), the sewing machine stops once. Function of prohibiting start of the sewing machine after thread trimming is operative.	0 to 2	<input type="text" value=""/> <input type="text" value=""/> <input type="text" value=""/> <input type="text" value="0"/>	
15	Thread clamp function at the start of sewing	Operation of the thread clamp at the start of sewing is set. 0 : Thread clamp does not operate 1 : Thread clamp operates	0/1	<input type="text" value=""/> <input type="text" value=""/> <input type="text" value=""/> <input type="text" value="1"/>	
21	Function of automatic presser foot lifting at pedal's neutral position	Function of lifting presser foot when the pedal is in neutral position. 0 : Function of neutral automatic presser lifting is not operative. 1 : Selection of function of neutral presser lifting.	0/1	<input type="text" value=""/> <input type="text" value=""/> <input type="text" value=""/> <input type="text" value="0"/>	
22	Needle up/down correction switch changeover function	Function of the needle up/down correction switch is changed over. 0 : Needle up/down compensation 1 : One stitch compensation	0/1	<input type="text" value=""/> <input type="text" value=""/> <input type="text" value=""/> <input type="text" value="0"/>	35
25	Thread trimming operation after turning the handwheel by hand	Thread trimming operation after moving the needle away from its upper or lower position by turning the handwheel by hand is specified. 0 : Thread trimming operation is carried out after turning the handwheel by hand. 1 : Thread trimming operation is not carried out after turning the handwheel by hand.	0/1	<input type="text" value=""/> <input type="text" value=""/> <input type="text" value=""/> <input type="text" value="1"/>	
27	Thread clamp sewing speed	The sewing speed when the thread clamp operates is set.	100 to MAX (sti/min)	<input type="text" value=""/> <input type="text" value="3"/> <input type="text" value="0"/> <input type="text" value="0"/>	
29	Back-tack initial operation time	This function sets the suction time of initial motion of back-tack solenoid.	50 to 500 (ms)	<input type="text" value=""/> <input type="text" value=""/> <input type="text" value="7"/> <input type="text" value="0"/>	35
30	Function of reverse feed stitching on the way	Function of reverse feed stitching on the way 0 : Normal one-touch type reverse feed stitching function 1 : Function of reverse feed stitching on the way is operative. (In the case the function of reverse feed stitching on the way is enabled, function No. 26 cannot be used.)	0/1	<input type="text" value=""/> <input type="text" value=""/> <input type="text" value=""/> <input type="text" value="0"/>	35
31	Number of stitches of reverse feed stitching on the way	Number of stitches of reverse feed stitching on the way	0 to 19 (Stitches)	<input type="text" value=""/> <input type="text" value=""/> <input type="text" value=""/> <input type="text" value="4"/>	35
32	Effective condition of reverse feed stitching on the way when the sewing machine is stopping.	Effective condition of reverse feed stitching on the way 0 : Function is not operative when the sewing machine stops. 1 : Function is operative when the sewing machine stops.	0/1	<input type="text" value=""/> <input type="text" value=""/> <input type="text" value=""/> <input type="text" value="0"/>	35
33	Thread trimming function by reverse feed stitching on the way	Thread trimming function by reverse feed stitching on the way 0 : Automatic thread trimming function after completion of reverse feed stitching on the way is not operative. 1 : Automatic thread trimming after completion of reverse feed stitching on the way is performed.	0/1	<input type="text" value=""/> <input type="text" value=""/> <input type="text" value=""/> <input type="text" value="0"/>	35

* Do not change the set values with asterisk (*) mark as they are functions for maintenance. If the standard set value set at the time of delivery is changed, it is in danger of causing the machine to be broken or the performance to be deteriorated. If it is necessary to change the set value, please purchase the Engineer's Manual and follow the instructions.

No.	Item	Description	Setting range	Default	Ref. page
* 35	Sewing speed at a low speed	Lowest speed by pedal (The MAX value differs by machine head.)	150 to MAX (sti/min)	<input type="text" value="2"/> <input type="text" value="0"/> <input type="text" value="0"/> <input type="text" value="0"/>	
* 36	Sewing speed of thread trimming	Thread trimming speed (The MAX value differs by machine head.)	100 to MAX (sti/min)	<input type="text" value="4"/> <input type="text" value="2"/> <input type="text" value="0"/> <input type="text" value="0"/>	
37	Sewing speed of soft-start	Sewing speed at the start of sewing (soft-start) (The MAX value differs by machine head.)	100 to MAX (sti/min)	<input type="text" value="8"/> <input type="text" value="0"/> <input type="text" value="0"/> <input type="text" value="0"/>	31
38	Sewing speed of one-shot stitching	Sewing speed of one-shot stitching (The MAX value differs by machine head.)	150 to MAX (sti/min)	<input type="text" value="2"/> <input type="text" value="5"/> <input type="text" value="0"/> <input type="text" value="0"/>	36
* 39	Operation-start pedal stroke	The pedal position at which the sewing machine starts operation from the neutral position of the pedal (Pedal stroke)	10 to 50 (0.1 mm)	<input type="text" value=""/> <input type="text" value=""/> <input type="text" value="3"/> <input type="text" value="0"/>	
* 40	Low speed section of pedal	Position where the sewing machine starts accelerating from pedal neutral position (Pedal stroke)	10 to 100 (0.1 mm)	<input type="text" value=""/> <input type="text" value=""/> <input type="text" value="6"/> <input type="text" value="0"/>	
* 41	Starting position of lifting presser foot by pedal	Position where the cloth presser starts lifting from pedal neutral position (Pedal stroke)	- 60 to -10 (0.1mm)	<input type="text" value=""/> <input type="text" value="-"/> <input type="text" value="2"/> <input type="text" value="1"/>	
* 42	Starting position of lowering presser foot	Starting position of lowering presser foot Stroke from the neutral position	8 to 50 (0.1 mm)	<input type="text" value=""/> <input type="text" value=""/> <input type="text" value="1"/> <input type="text" value="0"/>	
* 43	Pedal stroke 2 for starting thread trimming	Position 2 where the thread trimming starts from pedal neutral position (When the function of lifting presser foot by pedal is provided.) (Pedal stroke)	- 60 to -10 (0.1 mm)	<input type="text" value=""/> <input type="text" value="-"/> <input type="text" value="5"/> <input type="text" value="1"/>	
* 44	Pedal stroke for reaching the maximum sewing speed	Position where the sewing machine reaches its highest sewing speed from pedal neutral position (Pedal stroke)	10 to 150 (0.1 mm)	<input type="text" value=""/> <input type="text" value="1"/> <input type="text" value="5"/> <input type="text" value="0"/>	
* 45	Corrected neutral position of the pedal	The neutral position of the pedal sensor is set.	-15 to 15 (0.1 mm)	<input type="text" value=""/> <input type="text" value=""/> <input type="text" value=""/> <input type="text" value="0"/>	
47	Auto-lifter selecting function	Limitation time of waiting for lifting solenoid type auto-lifter device	10 to 600 (second)	<input type="text" value=""/> <input type="text" value=""/> <input type="text" value="6"/> <input type="text" value="0"/>	36
* 48	Pedal stroke 1 for starting thread trimming	Position where thread trimming starts from pedal neutral position (Standard pedal) (Pedal stroke)	- 60 to - 10 (0.1 mm)	<input type="text" value=""/> <input type="text" value="-"/> <input type="text" value="3"/> <input type="text" value="5"/>	
49	Lowering time of presser foot	Sets the time required until the lowering of the presser foot is completed after a depress on the pedal.	0 to 500 (10 ms)	<input type="text" value=""/> <input type="text" value="1"/> <input type="text" value="4"/> <input type="text" value="0"/>	39
* 50	Pedal specification	Type of pedal is selected. 0 : Presser foot is not operated by the pedal (KFL) 1 : Presser foot is operated by the pedal (PFL)	0/1	<input type="text" value=""/> <input type="text" value=""/> <input type="text" value=""/> <input type="text" value="0"/>	42
51	Compensation of solenoid-on timing of reverse feed stitching at the start of sewing	Compensation of starting the solenoid for reverse feed stitching when reverse feed stitching at the start of sewing is performed.	- 36 to 36 (10°)	The setting differs with the machine head.	37
52	Compensation of solenoid-off timing of reverse feed stitching at the start of sewing	Compensation of releasing the solenoid for reverse feed stitching when reverse feed stitching at the start of sewing is performed.	- 36 to 36 (10°)	The setting differs with the machine head.	37
53	Compensation of solenoid-off timing of reverse feed stitching at the end of sewing	Compensation of releasing the solenoid for reverse feed stitching when reverse feed stitching at the end of sewing is performed.	- 36 to 36 (10°)	The setting differs with the machine head.	37
55	Foot lift after thread trimming	Function of lifting presser foot at the time of (after) thread trimming 0 : Not provided with the function of automatic lifting of work-clamp after thread trimming 1 : Provided with the function of lifting presser foot automatically after thread trimming	0/1	<input type="text" value=""/> <input type="text" value=""/> <input type="text" value=""/> <input type="text" value="1"/>	38
56	Reverse revolution to lift the needle after thread trimming	Function of reverse revolution to lift the needle at the time of (after) thread trimming 0 : Not provided with the function of reverse revolution to lift the needle after thread trimming 1 : Provided with the function of reverse revolution to lift the needle after thread trimming	0/1	<input type="text" value=""/> <input type="text" value=""/> <input type="text" value=""/> <input type="text" value="0"/>	38
58	Function of holding predetermined upper/lower position of the needle bar	Function of holding predetermined upper/lower position of the needle bar 0 : Not provided with the function of holding predetermined upper/lower position of the needle bar 1 : Provided with the function of holding predetermined upper/lower position of the needle bar (Holding force is weak.) 2 : Provided with the function of holding predetermined upper/lower position of the needle bar (Holding force is medium.) 3 : Provided with the function of holding predetermined upper/lower position of the needle bar (Holding force is strong.)	0 to 3	<input type="text" value=""/> <input type="text" value=""/> <input type="text" value=""/> <input type="text" value="0"/>	38
59	Function of Auto/Manual change-over of reverse feed stitching at the start of sewing	This function can specify the sewing speed of reverse feed stitching at the start of sewing. 0 : The speed will depend on the manual operation by pedal, etc. 1 : The speed will depend on the specified reverse feed stitching speed (No. 8).	0/1	<input type="text" value=""/> <input type="text" value=""/> <input type="text" value=""/> <input type="text" value="1"/>	38
60	Function of stop immediately after reverse feed stitching at the start of sewing	Function at the time of completion of reverse feed stitching at the start of sewing 0 : Not provided with the function of temporary stop of the sewing machine at the time of completion of reverse feed stitching at the start of sewing 1 : Provided with the function of temporary stop of the sewing machine at the time of completion of reverse feed stitching at the start of sewing	0/1	<input type="text" value=""/> <input type="text" value=""/> <input type="text" value=""/> <input type="text" value="0"/>	39

* Do not change the set values with asterisk (*) mark as they are functions for maintenance. If the standard set value set at the time of delivery is changed, it is in danger of causing the machine to be broken or the performance to be deteriorated. If it is necessary to change the set value, please purchase the Engineer's Manual and follow the instructions.

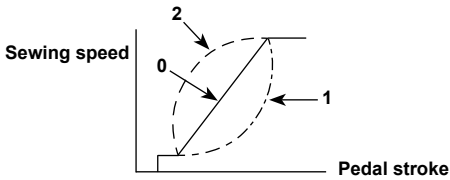
No.	Item	Description	Setting range	Default	Ref. page
64	Change-over speed of condensation stitch or EBT (end back tack)	Initial speed when starting condensation stitch or EBT	0 to 250 (sti/min)	<input type="text" value="1"/> <input type="text" value="8"/> <input type="text" value="0"/>	
70	Function of soft-down of presser foot	Presser foot is slowly lowered. 0 : Presser foot is rapidly lowered. 1 : Presser foot is slowly lowered.	0/1	<input type="text" value=""/> <input type="text" value=""/> <input type="text" value=""/> <input type="text" value="0"/>	39
71	Double reverse feed stitching function	Effective/ineffective of double reverse feed stitching is changed over. (Only used when the CP-18 is used.) 0 : Ineffective 1 : Effective	0/1	<input type="text" value=""/> <input type="text" value=""/> <input type="text" value=""/> <input type="text" value="1"/>	
72	Sewing machine startup selecting function	Current limit at the startup of sewing machine is specified. 0 : Normal (Current limit is applied during startup.) 1 : Rapid (Current limit is not applied during startup.)	0/1	<input type="text" value=""/> <input type="text" value=""/> <input type="text" value=""/> <input type="text" value="0"/>	
73	Retry function	This function is used when needle cannot pierce materials . 0 : Retry function is not provided. 1 to 10 : Retry function is provided. (Setting of the needle bar returning force)	0 to 10	<input type="text" value=""/> <input type="text" value=""/> <input type="text" value=""/> <input type="text" value="1"/>	39
* 76	One-shot function	One-shot operation up to the material end is specified. 0 : One-shot operation is not performed. 1 : One-shot operation is performed.	0/1	<input type="text" value=""/> <input type="text" value=""/> <input type="text" value=""/> <input type="text" value="0"/>	
84	Initial motion suction time of presser foot lifting solenoid	Suction motion time of presser foot lifting solenoid	50 to 500 (ms)	<input type="text" value="2"/> <input type="text" value="5"/> <input type="text" value="0"/>	39
87	Function of pedal curve selection	Pedal curve is selected. (Improving pedal inching operation) 	0 to 2	<input type="text" value=""/> <input type="text" value=""/> <input type="text" value=""/> <input type="text" value="0"/>	40
90	Initial motion up stop function	Automatic UP stop function is set immediately after turning ON the power. 0 : OFF 1 : ON	0/1	<input type="text" value=""/> <input type="text" value=""/> <input type="text" value=""/> <input type="text" value="1"/>	40
91	Function of prohibiting compensation operation after turning handwheel by hand	It is effective in combination with the machine head provided with tension release function. 0 : Tension release function is ineffective. 1 : Tension release function is effective.	0/1	<input type="text" value=""/> <input type="text" value=""/> <input type="text" value=""/> <input type="text" value="1"/>	
92	Function of reducing speed of reverse feed stitching at the start of sewing	Function to reduce speed at the time of completion of reverse feed stitching at the start of sewing. 0 : Speed is not reduced. 1 : Speed is reduced.	0/1	<input type="text" value=""/> <input type="text" value=""/> <input type="text" value=""/> <input type="text" value="1"/>	39
93	Function added to needle up/down compensating switch	Operation of needle up/down compensating switch is changed after turning ON the power or thread trimming. 0 : Normal (Needle up/down compensating stitching only) 1 : One stitch compensating stitching is performed only when aforementioned changeover is made. (Upper stop / upper stop)	0/1	<input type="text" value=""/> <input type="text" value=""/> <input type="text" value=""/> <input type="text" value="0"/>	40
95	Head selection function	Machine head to be used is selected. (When the machine head is changed, each setting item is changed to the initial value of the machine head.)		<input type="text" value=""/> <input type="text" value=""/> <input type="text" value=""/> <input type="text" value=""/>	
96	Max. sewing speed	Max. sewing speed of the sewing machine head can be set. (The MAX value differs by machine head.)	150 to MAX (sti/min)	The setting differs with the machine head.	40
103	Needle cooler output OFF delay time	Delay time from the stop of sewing machine to the output OFF is specified using the needle cooler output function.	100 to 2000 (ms)	<input type="text" value="5"/> <input type="text" value="0"/> <input type="text" value="0"/>	
120	Main shaft reference angle compensation	Main shaft reference angle is compensated.	-50 to 50	<input type="text" value=""/> <input type="text" value="-"/> <input type="text" value="1"/> <input type="text" value="3"/>	40
121	Up position starting angle compensation	Angle to detect UP position starting is compensated.	-15 to 15	<input type="text" value=""/> <input type="text" value=""/> <input type="text" value=""/> <input type="text" value="5"/>	40
122	DOWN position starting angle compensation	Angle to detect DOWN position starting is compensated.	-15 to 15	<input type="text" value=""/> <input type="text" value=""/> <input type="text" value=""/> <input type="text" value="0"/>	40
150	Correction of the thread clamp speed at the start of sewing	Speed correction coefficient for the function of the thread clamp at the start of sewing is set.	10 to 200	<input type="text" value="1"/> <input type="text" value="0"/> <input type="text" value="0"/>	
151	Thread clamp ON angle	The angle at which the thread clamp is turned ON at the start of sewing is set.	0 to 359 (°)	<input type="text" value="2"/> <input type="text" value="1"/> <input type="text" value="0"/>	
152	Thread clamp OFF angle	The angle at which the thread clamp is turned OFF at the start of sewing is set.	0 to 359 (°)	<input type="text" value="2"/> <input type="text" value="9"/> <input type="text" value="0"/>	
181	Setting of a target value for the production support function	A target value for the sewing counter of the production support function is set.	0 to 9999	<input type="text" value=""/> <input type="text" value=""/> <input type="text" value=""/> <input type="text" value="0"/>	

* Do not change the set values with asterisk (*) mark as they are functions for maintenance. If the standard set value set at the time of delivery is changed, it is in danger of causing the machine to be broken or the performance to be deteriorated. If it is necessary to change the set value, please purchase the Engineer's Manual and follow the instructions.

No.	Item	Description	Setting range	Default	Ref. page
182	Operation to be conducted when the target value is achieved	Operation to be carried out when the sewing counter of the production support function reaches the target value is set. 0 : No operation 1 : The sewing machine does not operate even if the pedal is depressed. * In the case the function No. 13 is used, the setting of the function No. 182 is disabled.	0/1	<input type="text" value=""/> <input type="text" value=""/> <input type="text" value=""/> <input type="text" value="0"/>	
183	Setting of the number of times of thread trimming for the production support function	The number of times of thread trimming at which the sewing counter of the production support function stops counting is set. 0 : The sewing counter stops counting when a value is entered to the sewing counter using the optional input/output function. 1 to 20 : The sewing counter stops counting according to the preset number of times of thread trimming	0 to 20	<input type="text" value=""/> <input type="text" value=""/> <input type="text" value=""/> <input type="text" value="1"/>	
186	Soft start resetting angle	An angle at which the start is reset is set. * This setting is enabled when the thread clamp operates.	180 to 900	<input type="text" value=""/> <input type="text" value="7"/> <input type="text" value="8"/> <input type="text" value="0"/>	

* Do not change the set values with asterisk (*) mark as they are functions for maintenance. If the standard set value set at the time of delivery is changed, it is in danger of causing the machine to be broken or the performance to be deteriorated. If it is necessary to change the set value, please purchase the Engineer's Manual and follow the instructions.

9. Detailed explanation of selection of functions

① Selection of the soft-start function (Function setting No. 1)

The needle thread may fail to interlace with the bobbin thread at the start of sewing when the stitching pitch (stitch length) is small or a thick needle is used. To solve such problem, this function (called "soft-start") is used to limit the sewing speed, thereby assuring successful formation of the starting stitches.

* This setting is enabled when the thread clamp function is in the OFF state.

n. 1

0 : The function is not selected.

1 to 9 : The number of stitches to be sewn under the soft-start mode.

The sewing speed limited by the soft-start function can be changed. (Function setting No. 37)

n. 3 7

Data setting range : 00 to MAX. sti/min <10 sti/min>

(The MAX. value differs by machine head.)

② Flicker reducing function (Function setting No. 5)

The function reduces flickering of the hand lamp at the start of sewing.

n. 5

0 : Flicker reducing function is ineffective

1 : Flicker reducing function is effective

(Caution) When the flicker reducing function is set at the "Flicker reducing function is effective," the startup speed of the sewing machine decreases.

③ Selection of the optional input/output function (Function setting No. 12)

For some of the input/output ports, their functions can be changed.

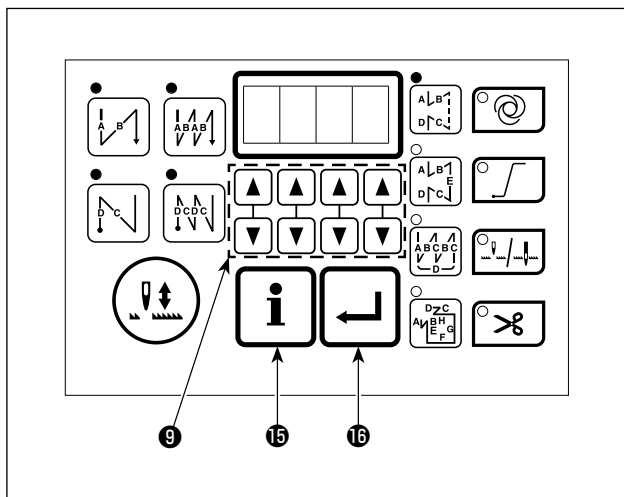

- 1) Select function setting No. 12 with the operating procedure of function setting procedures 1) through 3). Press switch 16.
- 2) Referring to the tables on p.33 to p.34, select display No. (i1 to i5, o1 to o3) corresponding to the connector number to which optional input/output is to be assigned, using switches 9. Then, press switch 16.
- 3) Referring to the tables on p.33 to p.34, select optional input/output signal to be assigned, using switches 9. Then, press switch 16.
- 4) Activate the signal using switches 9. Then, press switch 16.

Example) To assign the thread trimming function to the input port "i01"



n. 1 2

1) Select function setting No. 12 with the operating procedure of function setting procedures 1) through 3).

i. 1

2) Press  switch 16.

i. 1

3) Select a port (for example, "i1") to be set by pressing   switches 9.

b T

4) Press  switch 16.



T r M

5) Select a function (for example, "Trm") by pressing   switches 9.

L 0

6) Press  switch 16.

L 0 to H 0

7) Activate the selected function by pressing   switches 9.

i. 0

8) Press  switch 16.

9) Finish function setting by pressing  switch 15.

Input function list

Function code	Abbreviation	Function item	Remarks
0	noP	No function	(Standard setting)
1	HS	Needle up / down compensating stitching	Every time the switch is pressed, normal feed stitching by half stitch is performed. (Same operation as that of up / down compensating stitching switch on the panel.)
2	bHS	Back compensating stitching	Reverse feed stitching is performed at low speed while the switch is held pressing.
3	EbT	Function of canceling once reverse feed stitching at the end of sewing	By depressing the back part of the pedal after pressing the switch, operation of reverse feed stitching is canceled once.
4	TSW	Thread trimming function	This function is actuated as the thread trimming switch.
5	FL	Presser foot lifting function	This function is actuated as the foot lifter switch.
6	oHS	One stitch compensating stitching	Every time the switch is pressed, one stitch stitching operation is executed.
7	SEbT	Function of cancel of reverse feed stitching at start/end	By operating the optional switch, ineffective/effective can be alternately changed over.
8	Ed	Material edge sensor input	This function works as the input signal of material edge sensor.
9	LinH	Function of prohibiting depressing front part of pedal	Rotation by pedal is prohibited.
10	TinH	Function of prohibiting thread trimming output	Output of thread trimming is prohibited.
11	LSSW	Low speed command input	This function works as low speed switch for standing sewing machine.
12	HSSW	High speed command input	This function works as high speed switch for standing sewing machine.
13	USW	Needle lifting function	UP stop motion is performed when switch is pressed during DOWN stop.
14	bT	Reverse feed stitching switch input	Reverse feed stitching is output as long as the switch is held pressed.
15	SoFT	Soft start switch input	The speed of stitch is limited to the predetermined soft-start speed as long as the switch is held pressed.
16	oSSW	One-shot speed command switch input	This function works as one-shot speed command as long as the switch is pressed.
17	bKoS	Backward one-shot speed command switch input	Reverse feed stitching is performed in accordance with the one-shot speed command as long as the switch is held pressed.
18	SFSW	Safety switch input	Rotation is prohibited.
19	AUbT	Automatic reverse feed stitching cancellation/addition switch	Every time the switch is pressed, reverse feed stitching at sewing start or reverse feed stitching at sewing end is canceled or added.
20	CUnT	Sewing counter input	Every time the switch is pressed, the sewing counter value is increased.

Input function connectors

Connector No.	Pin No.	Display No.	Function	Initial value of No. 12
CN22	5	i.1	Reverse feed stitching switch input	bT
CN20	7	i.2	Thread trimming switch input	TSW
CN20	11	i.3	Low-speed revolution switch input	LSSW
CN20	9	i.4	High-speed revolution switch input	HSSW
CN20	5	i.5	Presser foot lifting switch input	FL

Output function list

Function code	Abbreviation	Function item	Remarks
0	noP	No function	(Standard setting)
1	TrM	Thread trimming output	Output of thread trimming signal
2	WiP	Thread wiper output	Output of thread wiper signal
3	TL	Thread release output	Output of thread release signal
4	FL	Presser lifter output	Output of presser lifting signal
5	bT	Reverse feed stitching output	Output of reverse feed stitching signal
6	EbT	EBT cancel monitor output	State of one time cancel of reverse feed stitching at end function is output.
7	SEbT	Reverse feed stitching at start/end cancel monitor output	State of cancel of reverse feed stitching at start/end is output.
8	AUbT	Sewing start/end cancellation/addition monitor output	State of cancel or addition of automatic reverse feed stitching is output.
9	SSTA	Sewing machine stop state output	Sewing machine stop state is output.
10	Cool	Needle cooler output	Output for needle cooler
11	bUZ	Buzzer output	It is output when the bobbin counter set value has been exceeded, an error has occurred or the bobbin thread remaining amount is detected.
12	LSWo	Revolution command output	Revolution demanding command state is output.

Output function connector

Connector No.	Pin No.	Display No.	Function	Initial value of No. 12
CN22	3	o.1	Reverse feed stitching output	bT
CN22	7	o.2	Thread trimming output	TrM
CN22	14	o.3	Revolution request input	LSWo

④ **Needle up/down switch function changeover function (Function setting No. 22)**

The needle up/down switch function can be changed over between the needle up/down compensation and one stitch compensation.

- n. **2 2** 0 : Needle up / down compensating stitching
 1 : One stitch compensating stitching

⑤ **Setting of the suction time of the back-tack solenoid (Function setting No. 29)**

This function can change the suction time of the back-tack solenoid. It is effective to decrease the value when the heat is high.

(Caution) When the value is excessively decreased, failure of motion or defective pitch will follow.

Be careful when changing the value.

- n. **2 9** Setting range : 50 to 500 ms <10 / ms>

⑥ **Function of reverse feed stitching on the way (Function setting Nos. 30 to 33)**

Functions of the limit of number of stitches and thread trimming command can be added to the touch back switch on the sewing machine head.

Function setting No. 30 Function of reverse feed stitching on the way is selected.

- n. **3 0** 0 : OFF Normal back-tack function
 1 : ON Function of reverse feed stitching on the way

Function setting No. 31 Number of stitches performing reverse feed stitching is set.

- n. **3 1** Setting range : 0 to 19 stitches

Function setting No. 32 Effective condition of reverse feed stitching on the way

- n. **3 2** 0 : OFF Inoperative when the sewing machine stops. (Reverse feed stitching on the way functions only when the sewing machine is running.)
 1 : ON Operative when the sewing machine stops. (Reverse feed stitching on the way functions both when the sewing machine is running and stops.)

(Caution) Either condition is operative when the sewing machine is running.

Function setting No. 33 Thread trimming is performed when reverse feed stitching on the way is completed.

- n. **3 3** 0 : OFF Without thread trimming
 1 : ON Thread trimming is executed.

Application	Function setting			Output function
	No.30	No.32	No.33	
①	0	0 or 1	0 or 1	It works as normal touch-back switch.
②	1	0	0	When operating touch-back switch at the time of depressing front part of the pedal, reverse feed stitching as many as the number of stitches specified by the function setting No. 31 can be performed.
③	1	1	0	When operating touch-back switch at the time of either stop of the sewing machine or depressing front part of the pedal, reverse feed stitching as many as the number of stitches specified by the function setting No. 31 can be performed.
④	1	0	1	When operating touch-back switch at the time of depressing front part of the pedal, automatic thread trimming is performed after reverse feed stitching as many as the number of stitches specified by the function setting No. 31 has been performed.
⑤	1	1	1	When operating touch-back switch at the time of either stop of the sewing machine or depressing front part of the pedal, automatic thread trimming is performed after reverse feed stitching as many as the number of stitches specified by the function setting No. 31 has been performed.

Actions under each setting state

- ① Used as the normal reverse feed stitching touch-back switch.
- ② Used for reinforcing seam (press sewing) of the pleats. (It works only when the sewing machine is running.)
- ③ Used for reinforcing seam (press sewing) of the pleats. (It works either when the sewing machine stops or when the sewing machine is running.)
- ④ Used as starting switch for reverse feed stitching at the sewing end. (Used as the substitute for thread trimming by depressing back part of the pedal. It works only when the sewing machine is running. It is especially effective when the sewing machine is used as the standing-work machine.)
- ⑤ Used as starting switch for reverse feed stitching at the sewing end. (Used as the substitute for thread trimming by depressing back part of the pedal. It works either when the sewing machine stops or when the sewing machine is running. It is especially effective when the sewing machine is used as the standing-work machine.)

⑦ Sewing speed of one-shot stitching (Function setting No. 38)

This function can set, by the pedal operation of one time, the sewing speed of one-shot stitching when the sewing machine continues stitching until completing the number of stitches specified or detecting the material end.

Setting range : 150 to MAX. sti/min. <50 / sti/min>

(Caution) The max. sewing speed of one-shot stitching is limited by the model of the sewing machine head.

⑧ Holding time of lifting presser foot (Function setting No. 47)

This function automatically lowers the presser foot when the time set with the setting No. 47 has passed after lifting the presser foot.

When the pneumatic type presser foot lifter is selected, the holding time control of lifting presser foot is limitless regardless of the set value.

Setting range : 10 to 600 sec <10 / sec>

⑨ **Compensation of timing of the solenoid for reverse feed stitching (Function setting No. 51 to 53)**

When the normal and reverse feed stitches are not uniform under the automatic reverse feed stitching action, this function can change the ON / OFF timing of the solenoid for back tack and compensate the timing.

❶ **Compensation of on-timing of solenoid for reverse feed stitching at the start of sewing (Function setting No. 51)**

On-timing of solenoid for reverse feed stitching at the start of sewing can be compensated by the unit of angle.

n. **5** **1** Adjusting range : - 36 to 36 <1 / 10°>

Set value	Compensation angle	Number of stitches of compensation
- 36	- 360°	- 1
- 18	- 180°	- 0.5
0	0°	0
18	180°	0.5
36	360°	1

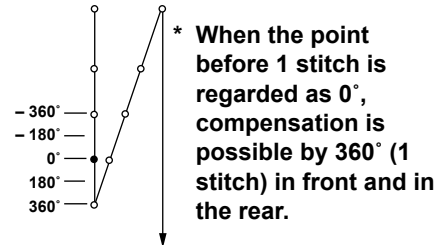

❷ **Compensation of off-timing of solenoid for reverse feed stitching at the start of sewing (Function setting No. 52)**

Off-timing of solenoid for reverse feed stitching at the start of sewing can be compensated by the unit of angle.

n. **5** **2** Adjusting range : - 36 to 36 <1 / 10°>

Set value	Compensation angle	Number of stitches of compensation
- 36	- 360°	- 1
- 18	- 180°	- 0.5
0	0°	0
18	180°	0.5
36	360°	1

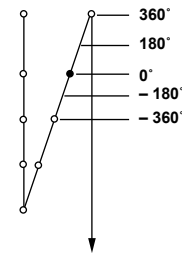

❸ **Compensation of off-timing of solenoid for reverse feed stitching at the end of sewing (Function setting No. 53)**

Off-timing of solenoid for reverse feed stitching at the start of sewing can be compensated by the unit of angle.

n. **5** **3** Adjusting range : - 36 to 36 <1 / 10°>

Set value	Compensation angle	Number of stitches of compensation
- 36	- 360°	- 1
- 18	- 180°	- 0.5
0	0°	0
18	180°	0.5
36	360°	1

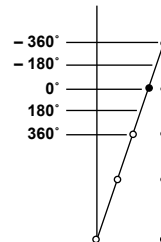

⑩ **Foot lift function after thread trimming (Function setting No. 55)**

This function can automatically lift the presser foot after thread trimming. This function is effective only when it is used in combination with the AK device.

- n.** **5** **5** 0 : OFF Function of automatically lifting the presser foot is not provided.
(Presser foot does not automatically go up after thread trimming.)
- 1 : ON Function of automatically lifting the presser foot is provided.
(Presser foot automatically goes up after thread trimming.)

⑪ **Reverse revolution to lift the needle after thread trimming (Function setting No. 56)**

This function is used to make the sewing machine rotate in the reverse direction after thread trimming to lift the needle bar almost to highest position.

Use this function when the needle appears under the presser foot and it is likely to make scratches on the sewing products of heavy-weight material or the like.

- n.** **5** **6** 0 : OFF Function of making the sewing machine rotate in the reverse direction to lift the needle after thread trimming is not provided.
- 1 : ON Function of making the sewing machine rotate in the reverse direction to lift the needle after thread trimming is provided.

(Caution) The needle bar is raised, by rotating the machine in the reverse direction, almost to the highest dead point. This may result in slip-off of the needle thread. It is therefore necessary to adjust the length of thread remaining after thread trimming properly.

⑫ **Function of holding predetermined upper / lower position of the needle bar (Function setting No. 58)**

When the needle bar is in the upper position or in the lower position, this function holds the needle bar by applying a brake slightly.

- n.** **5** **8** 0 : OFF Not provided with the function of holding predetermined upper/lower position of the needle bar
- 1 : ON Provided with the function of holding predetermined upper/lower position of the needle bar (Holding force is weak.)
- 2 : ON Provided with the function of holding predetermined upper/lower position of the needle bar (Holding force is medium.)
- 3 : ON Provided with the function of holding predetermined upper/lower position of the needle bar (Holding force is strong.)

⑬ **Change-over function of AUTO / Pedal for sewing speed of the reverse feed stitching at the start of sewing (Function setting No. 59)**

This function selects whether the reverse feed stitching at the start of sewing is performed without a break at the speed set by the function setting No. 8 or the stitching is performed at the speed by the pedal operation.

- n.** **5** **9** 0 : Manual The speed is indicated by the pedal operation.
- 1 : Auto Automatic stitching at the specified speed

(Caution) 1. The max. sewing speed of the reverse feed stitching at the start of sewing is limited to the speed set by the function setting No. 8 regardless of the pedal.

2. When "0" is selected, stitches of reverse feed stitching may not match those of normal feed stitching.

⑭ **Function of stop immediately after the reverse feed stitching at the start of sewing (Function setting No. 60)**

This function temporarily stops the sewing machine even when keeping depressing the front part of the pedal at the time of completion of process of reverse feed stitching at the start of sewing.

It is used when sewing a short length by reverse feed stitching at the start of sewing.

n. **6** **0**

0 : Not provided with the function of temporary stop of the sewing machine immediately after the reverse feed stitching at the start of sewing

1 : Provided with the function of temporary stop of the sewing machine immediately after the reverse feed stitching at the start of sewing

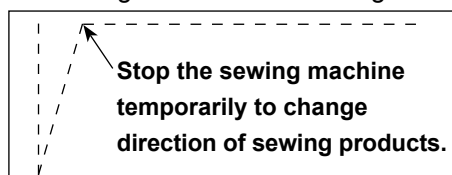

⑮ **Function of soft-down of presser foot (with AK device only) (Function setting No. 70 and 49)**

This function can softly lower the presser foot.

This function can be used when it is necessary to decrease contact noise, cloth defect, or slippage of cloth at the time of lowering the presser foot.

Note : Change the time of function setting No. 49 together at the time of selecting the function of soft-down since the sufficient effect cannot be obtained unless the time of function setting No. 49 is set longer when lowering the presser foot by depressing the pedal.

n. **4** **9**

Setting range : 0 to 500 ms <10 ms/Step>

n. **7** **0**

0 : Function of soft-down of presser foot is not operative. (Presser foot is rapidly lowered.)

1 : Selection of function of soft-down of presser foot

⑯ **Function of reducing speed of reverse feed stitching at the start of sewing (Function setting No. 92)**

Function to reduce speed at the time of completion of reverse feed stitching at the start of sewing :

Normal use depending on the pedal condition (Speed is accelerated to the highest without a break.) This function is used when temporary stop is used properly. (Cuff and cuff attaching)

n. **9** **2**

0 : Speed is not reduced.

1 : Speed is reduced.

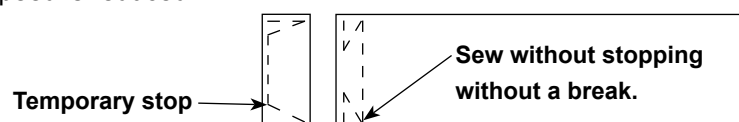

⑰ **Retry function (Function setting No. 73)**

When the retry function is used, if the sewing material is thick and not pierced with needle, this function makes the needle pierce in the material with ease.

n. **7** **3**

0 : Re-try function is not provided.

1 to 10 : Re-try function is provided. (Needle-bar returning force before re-trying: 1 (small) - 10 (large))

⑱ **Presser foot lifting solenoid suction time setting (Function setting No. 84)**

Suction time of presser foot lifting solenoid can be changed. When heating is great, it is effective to lessen the value.

(Caution) When the value is excessively small, malfunction will be caused. So, be careful when changing the value.

n. **8** **4**

Setting range : 50 to 500ms <10/ms>

①⑨ **Function of pedal curve selection (Function setting No. 87)**

This function can perform the selection of the curve of sewing speed of the sewing machine against the depressing amount of the pedal.

Change to this function when you feel that inching operation is hard or that pedal response is slow.

n. 8 7

- 0 : Sewing speed in terms of the depressing amount of the pedal increases linearly.
- 1 : Reaction to intermediate speed in terms of the depressing amount of the pedal is delayed.
- 2 : Reaction to intermediate speed in terms of the depressing amount of the pedal is advanced.

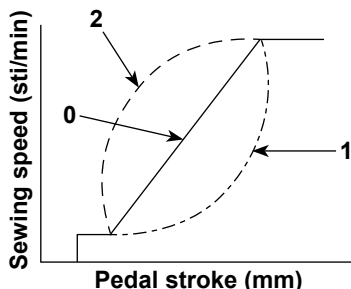

②⑩ **Initial motion UP stop position move function (Function setting No. 90)**

Effective/ineffective of automatic return to UP stop position immediately after turning ON the power can be set.

n. 9 0

- 0 : Ineffective
- 1 : Effective

②⑪ **Function added to the needle up / down compensating switch (Function setting No. 93)**

One stitch operation can be performed only when the needle up / down compensating switch is pressed at the time of upper stop immediately after turning ON the power switch or upper stop immediately after thread trimming.

n. 9 3

- 0 : Normal (Only needle up / down compensating stitching operation)
- 1 : One stitch compensating stitching operation (upper stop / upper stop) is performed only when aforementioned changeover is made.

②⑫ **Setting of max. sewing speed (Function setting No. 96)**

This function can set the max. sewing speed you desire to use.

Upper limit of the set value varies in accordance with the sewing machine head to be connected.

n. 9 6

Setting range : 150 to MAX. sti/min <50 / sti/min>

②⑬ **Main shaft reference angle compensation (Function setting No. 120)**

Main shaft reference angle is compensated

n. 1 2 0

Setting range : - 50 to 50° <1 / °>

②⑭ **UP position starting angle compensation (Function setting No. 121)**

Angle to detect UP position starting is compensated.

n. 1 2 1

Setting range : - 15 to 15° <1 / °>

②⑮ **DOWN position starting angle compensation (Function setting No. 122)**

Angle to detect DOWN position starting is compensated.

n. 1 2 2

Setting range : - 15 to 15° <1 / °>

10. Automatic compensation of neutral point of the pedal sensor

Whenever the pedal sensor, spring, etc. are replaced, be sure to perform following operation :



If you place your foot or any object on the pedal, the pedal will not operate properly. Operate the pedal with nothing placed on it.

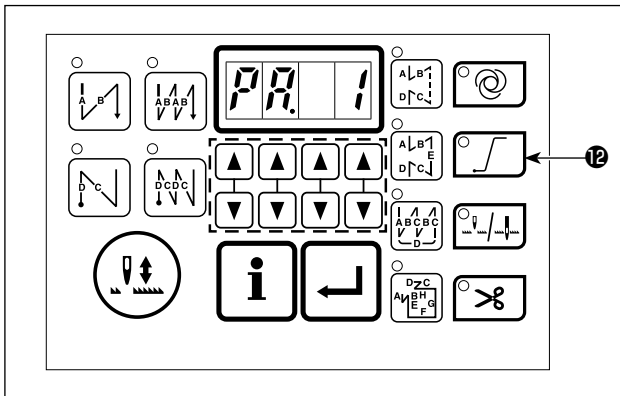

1) Pressing  switch 12, turn ON the power switch.

The panel display is as illustrated in the figure. The value indicated on the right side of "PA.", at this time, is the compensation value. (In this figure, the correction value is "1".)

2) The neutral position of the pedal is stored in memory. Turn the power OFF to finish the procedure.



In the case " $n \bar{L}$ " is displayed:

The pedal sensor is not properly connected. Turn the power OFF and check the connection of the pedal sensor.

In the case " PA_{-} " is displayed:

It is necessary to adjust the installation of the pedal. Carry out the adjustment of the installation of the pedal according to the below-stated "How to adjust the pedal".

How to adjust the pedal

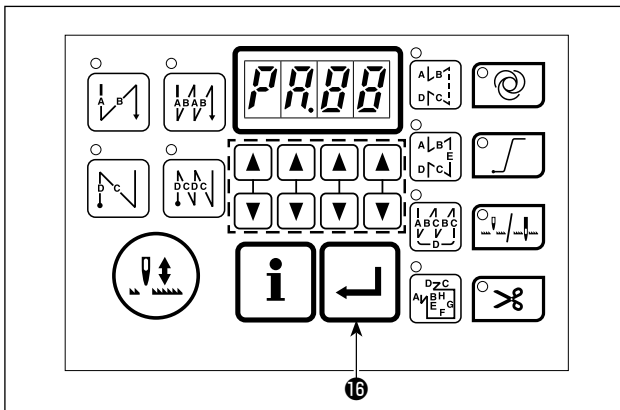

a) Check the digit which flashes on and off to determine the direction of pedal dislocation.

In the case the pedal sensor neutral position is displaced toward the front part of the pedal.

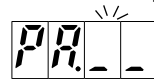

Flashes on and off

In the case the pedal sensor neutral position is displaced toward the rear part of the pedal.

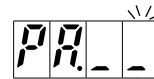

Flashes on and off

b) Adjust the installation of the pedal so that the indication " $PA.000$ " is displayed. (Refer to the Engineer's Manual for how to adjust the pedal.)

Correct the pedal in the direction to correct the pedal dislocation. When the dislocation is reduced to be within the permissible range, " $PA.000$ " is displayed.

c) Press  switch 16. The indication is changed to the state described in 1).

d) Now, the pedal adjustment is completed. Turn the power OFF.

11. Selection of the pedal specifications

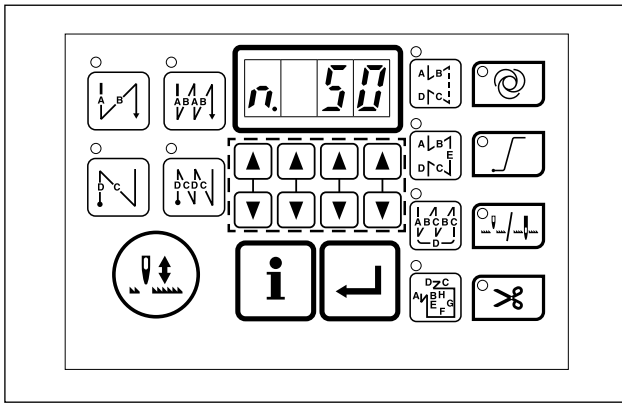

When the pedal sensor has been replaced, change the set value of function setting No. 50 according to the newly connected pedal specifications.

0 : KFL

1 : PFL

Pedal sensor with two springs located at the back part of the pedal type is PFL, and that with one spring type is KFL. Set the pedal sensor to PFL when lifting the presser foot by depressing the back part of the pedal.



12. Setting of the auto lifter function

When the auto-lifter device (AK) is attached, this function makes the function of auto-lifter work.

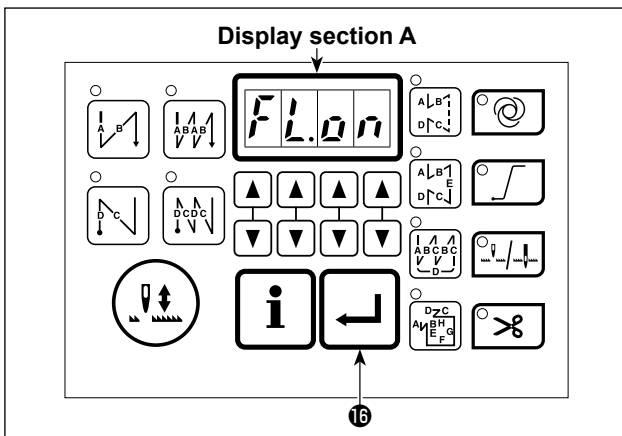

- 1) Turn ON the power switch with  switch **16** held pressed.
- 2) "FL.on" is displayed on indicator **A** with a blip to make the auto lifter function effective.
- 3) Turn OFF the power switch, and turn ON the power switch again to return to the normal mode.
- 4) Repeat the operation 1) to 3), and display is turned to "FL.of". Then, the function of auto-lifter does not work.

FL.on : Automatic presser lifter is provided. (AK is provided.)

FL.of : Automatic presser lifter is not provided.

1. To perform re-turning ON of the power, be sure to perform after the time of one second or more has passed.
(If ON / OFF operation of the power is performed quickly, setting may be not changed over well.)





2. Auto-lifter is not actuated unless this function is properly selected.
3. When "Automatic presser lifter is provided." is selected without installing the auto-lifter device, starting is momentarily delayed at the start of sewing. In addition, be sure to select "Automatic presser lifter is not provided." when the auto-lifter is not installed since the touch-back switch may not work.

13. Selecting procedure of the key-lock function

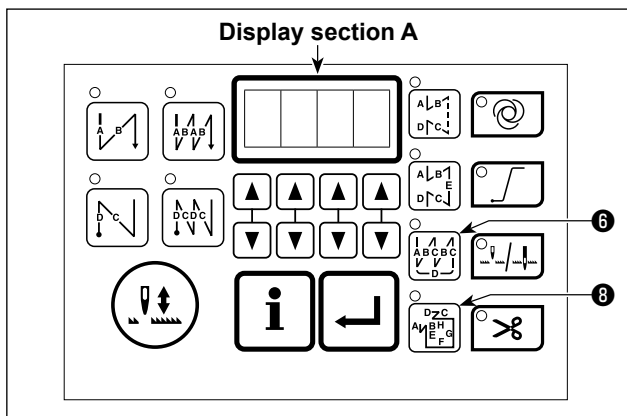
Setting of the number of stitches for a pattern can be prohibited by enabling the key lock function.



- 1) Turn ON the power switch with  switch **6** and  switch **8** held pressed.
- 2) "KL.on" is displayed on indicator **A** with a blip to make the key-lock function effective.
- 3) The panel returns to the normal operation after displaying "KL.on" on the indicators.
- 4) While the key lock function is effective, "KL.on" is displayed on the indicators when turning the power ON.

5) When you carry out steps 1) to 3) in repetition, "KL.of" is displayed when turning the power ON and the key lock function is rendered ineffective.

• "KL.on" display when turning the power ON

Display appears: The key lock function is effective.

Display does not appear: The key lock function is ineffective.



In the case the key lock function is effective, the operation of the panel will be as shown in the table below.

Switch operation of which is to be disabled.	<ul style="list-style-type: none"> • Setting of the reverse feed stitching (1, 2, 3 and 4) • Change of the sewing pattern (5, 6, 7 and 8) • Change of the number of stitches (9) • Change of the sewing operation (11, 12, 13 and 14)
Switch operation of which is not to be disabled.	<ul style="list-style-type: none"> • Compensating stitching in half-stitch steps (10) • Production support function (7)

14. Initialization of the setting data

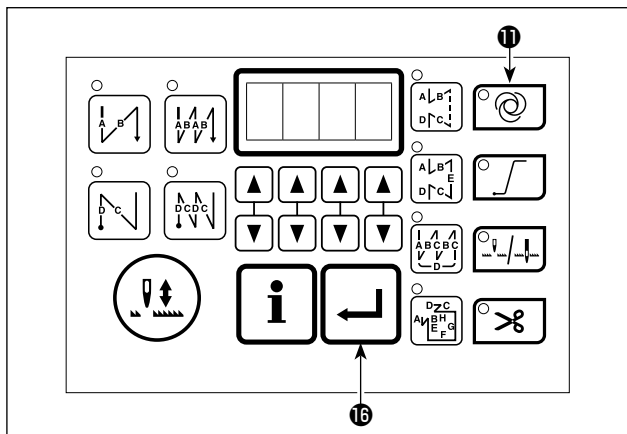
All contents of function setting can be returned to the standard set values.



- 1) Referring to the explanation of **"III-6. Setting of functions" p.24**, select function setting "n.95".
Then, press  switch **16**.
- 2) Press and hold  switch **11**.
- 3) The buzzer sounds after approximately one second, and the setting data returns to the standard setting value.

 **Do not turn OFF the power on the way of initializing operation. Program of the main unit may be broken.**

4) Turn OFF the power switch and turn ON the power switch after closing the front cover. The machine returns to the normal motion.

 **1. When you carry out the aforementioned operation, the neutral position correction value for the pedal sensor is also initialized. It is therefore necessary to carry out automatic correction of the pedal sensor neutral position before using the sewing machine. (Refer "III-10. Automatic compensation of neutral point of the pedal sensor" p.41.)**

2. When you carry out the aforementioned operation, the machine-head adjustment values and the function settings of the optional devices are also initialized. It is therefore necessary to carry out adjustment of the machine head before using the sewing machine. (Refer "IV-1. Adjusting the machine head" p.45.)

3. Even when this operation is performed, the sewing data set by the operation panel cannot be initialized.

15. LED hand light



WARNING :

In order to protect against personal injury due to unexpected start of the sewing machine, never bring hands near the needle entry area or place foot on the pedal during the adjustment of intensity of the LED.

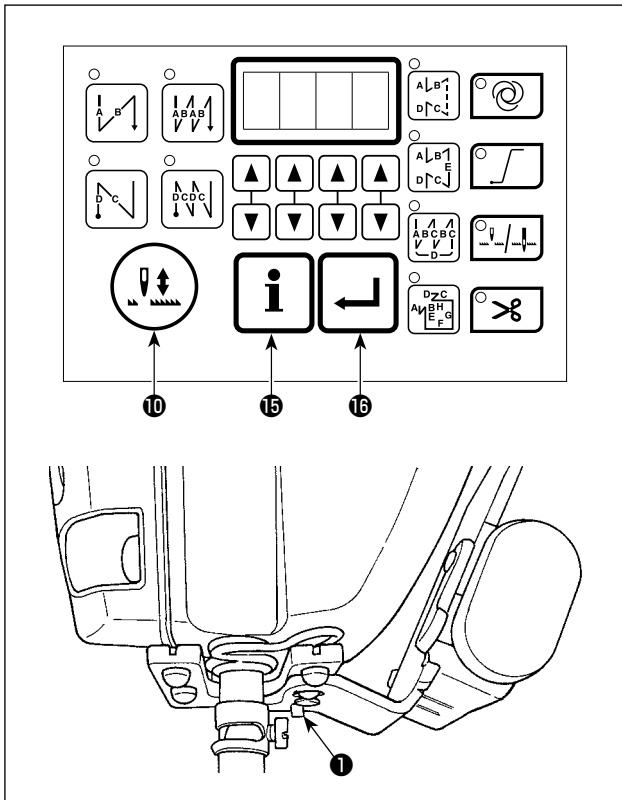

The sewing machine is provided as standard with an LED light which illuminates the needle entry area.

- 1) Turn the power ON while pressing  switch **15** to enter the function setting mode.
- 2) Intensity adjustment and turn-off of the light is carried out by pressing switch **1** mounted on the rear section of the LED. Every time the switch is pressed, the light is adjusted in intensity in five steps and is turned off in turn.

[Change of intensity]

1 ⇒ 4 ⇒ 5 ⇒ 6

Bright ⇒ Dim ⇒ Off ⇒ Bright

In this way, every time the switch **1** is pressed, the hand lamp status is changed in repetition.

- 3) Press  switch **10** to complete the procedure.

16. Height adjustable one-touch type reverse stitching switch

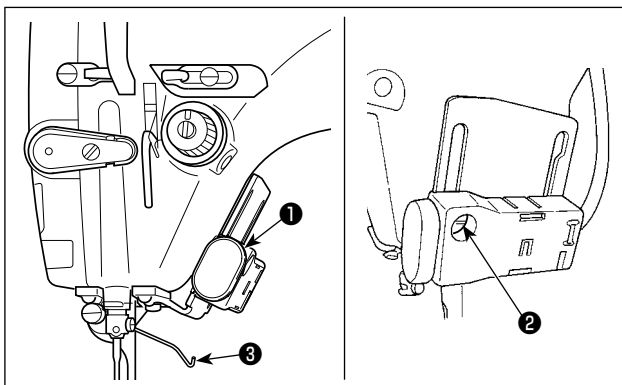

Height of touch-back switch **1** is adjustable.

For the process during which touch-back switch **1** is not used, the material on the sewing machine can be handled with ease by increasing the height of the switch.

[How to adjust the height]

The switch height can be adjusted along the bracket by loosening screw **2**.



To change the settings of wiper **3** from the factory-adjusted settings at the time of shipment for the purpose of adjustment, it is necessary to adjust the height of touch-back switch **1** so that it does not interfere with wiper **3**.



IV. MAINTENANCE

1. Adjusting the machine head

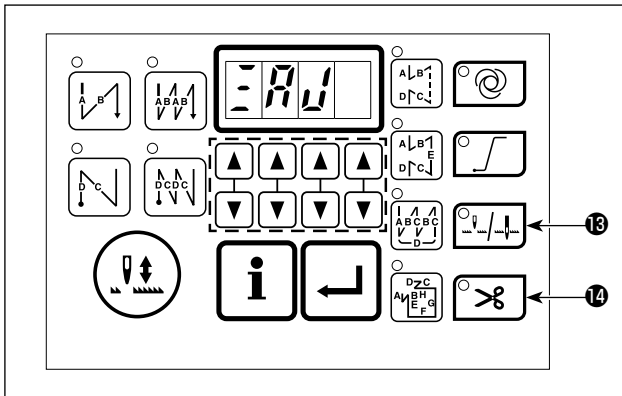

When the slip between the white marker dot on the handwheel and the concave of the cover is excessive after thread trimming, adjust the angle of the machine head by the operation below.



- 1) Turn the power ON while keeping  switch **13** and  switch **14** held pressed. "ZAJ" appears on the display section.

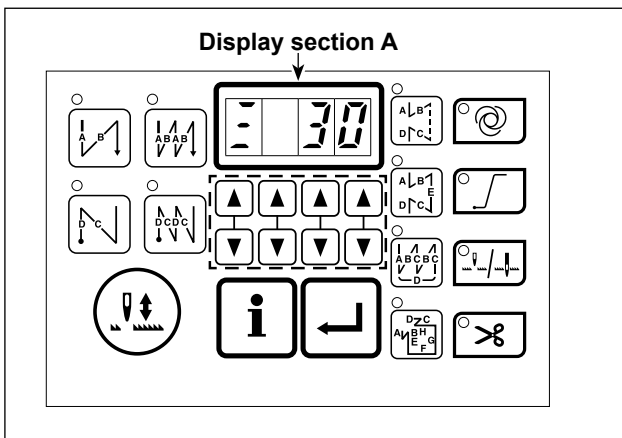

- 2) Turn the pulley of the machine head by hand until the main-shaft reference signal is detected. At this time, the degree of an angle from the main-shaft reference signal is displayed on the display section A. (The value is the reference value.)

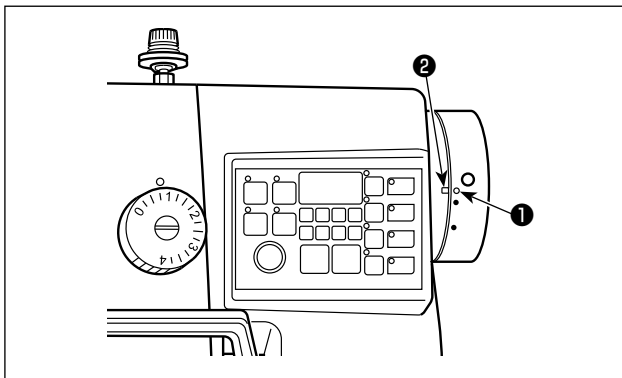

- 3) In this state, align the white dot **1** of the handwheel with the concave **2** of the pulley cover as shown in the figure.

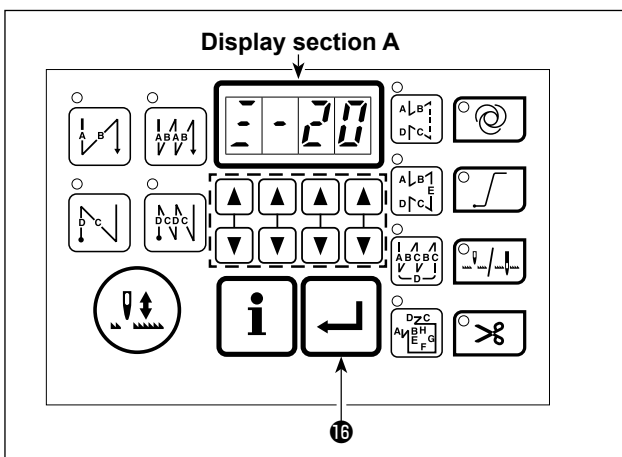

- 4) Press  switch **13** to finish the adjustment work. At this time, the value indicated on display section A is changed. (The value is the reference value.)
- 5) Turn the power OFF.

2. Error codes

In case of the following, check again before you judge the case as trouble.

Phenomenon	Cause	Corrective measure
When tilting the sewing machine, the buzzer beeps and the sewing machine cannot be operated. Solenoids for thread trimming	When tilting the sewing machine without turning OFF the power switch, Action given on the left side is taken for safety sake.	Tilt the sewing machine after turning OFF the power.
Solenoids for thread trimming, reverse feed, wiper, etc. fail to work. Hand lamp does not light up.	When the fuse for solenoid power protection has blown out	Check the fuse for solenoid power protection.
Even when depressing the pedal immediately after turning ON the power, the sewing machine does not run. When depressing the pedal after depressing the back part of pedal once, the sewing machine runs.	Neutral position of the pedal has varied. (Neutral position may be shifted when changing spring pressure of the pedal or the like.)	Execute the automatic neutral correction function of the pedal sensor.
The sewing machine does not stop even when the pedal is returned to its neutral position.		
Presser foot does not go up even when auto-lifter device is attached.	Auto-lifter function is OFF.	Select "Automatic presser lifter is provided." by auto-lifter function selection.
	Pedal system is set to KFL system.	Change the jumper to PFL setting to lift the presser foot by depressing the back part of the pedal.
	Cord of auto-lifter device is not connected to connector (CN37).	Connect the cord properly.
Touch-back switch fails to work.	Presser foot is going up by auto-lifter device.	Operate the switch after the presser foot lowered.
	Auto-lifter device is not attached. However, auto-lifter function is ON.	Select "Automatic presser lifter is not provided." when auto-lifter device is not attached.
Sewing machine fails to run.	Motor output cord (4P) is disconnected.	Connect the cord properly.
	Connector (CN30) of motor signal cord is disconnected.	Connect the cord properly.

In addition, there are the following error codes in this device. These error codes interlock (or limit function) and inform the problem so that the problem is not enlarged when any problem is discovered. When you request our service, please confirm the error codes.

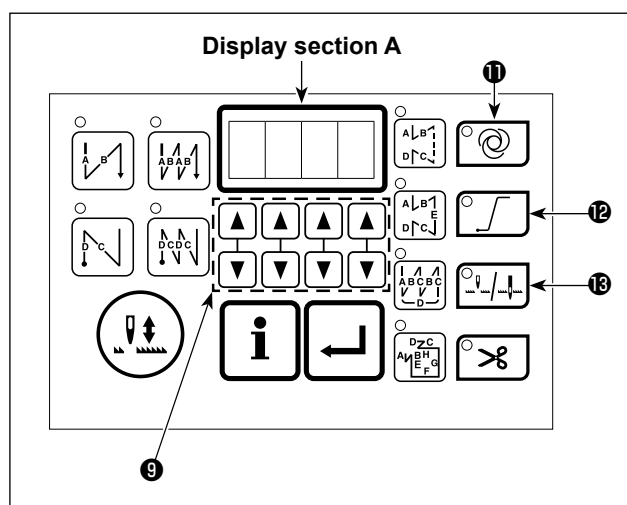

[Checking procedure of the error code]

- 1) Turn ON the power switch with switch ⑪ held pressed.
- 2) With a bleep, serial numbers of the errors which have occurred so far appear on the display section A.
- 3) Press and switches ⑨ to enable selection of the serial number. Select one of the serial numbers you want to check and, in this state, press switch ⑫ to display the energized time duration (upper four digits of hours and minutes), or press switch ⑬ to display the energized time duration (lower four digits of hours and minutes). (The aforementioned data are displayed as long as the corresponding switch is held pressed.)

Error code list

No.	Description of error detected	Cause of occurrence expected	Items to be checked
E000	Execution of data initialization (This is not the error.)	<ul style="list-style-type: none"> When the machine head is changed. When the initialization operation is executed. 	
E007	Overload of motor	<ul style="list-style-type: none"> When the machine head is locked. When sewing extra-heavy material beyond the guarantee of the machine head. When the motor does not run. Motor or driver is broken. 	<ul style="list-style-type: none"> Check whether the thread has been entangled in the motor pulley. Check the motor output connector (4P) for loose connection and disconnection. Check whether there is any holdup when turning the motor by hand.
E071	Disconnection of motor output connector	<ul style="list-style-type: none"> Disconnection of motor connector. 	<ul style="list-style-type: none"> Check the motor output connector for loose connection and disconnection.
E072	Overload of motor at the time of thread trimming motion	<ul style="list-style-type: none"> Same as E007. 	<ul style="list-style-type: none"> Same as E007.
E079	Continuous operation with the motor applied with a higher load	<ul style="list-style-type: none"> The machine has been operated with the motor applied with a load which is higher than the normal load. 	<ul style="list-style-type: none"> Check whether the thread has been entangled in the motor pulley. Check whether there is any holdup when turning the motor by hand.
E302	Fall detection switch failure (When the safety switch works)	<ul style="list-style-type: none"> When fall detection switch is input in the state that the power is turned ON. 	<ul style="list-style-type: none"> Check whether the machine head is tilted without turning OFF the power switch (sewing machine operation is prohibited for safety sake).
E303	Semicircular plate sensor error	<ul style="list-style-type: none"> Semicircular plate sensor signal cannot be detected. 	<ul style="list-style-type: none"> Check whether the motor encoder connector is disconnected.
E499 E704	Data fault	<ul style="list-style-type: none"> The stored data have broken. 	
E730	Encoder failure	<ul style="list-style-type: none"> When the motor signal is not properly inputted. 	<ul style="list-style-type: none"> Check the motor signal connector (CN30) for loose connection and disconnection. Check whether the motor signal cord has broken since the cord is caught in the machine head. Check whether the inserting direction of the motor encoder connector is wrong.
E731	Motor hole sensor failure		
E733	Inverse rotation of motor	<ul style="list-style-type: none"> This error occurs when the motor is running at 500 sti/min or more in the opposite direction of that of rotation indication during motor is running. 	<ul style="list-style-type: none"> Connection of the encoder of main shaft motor is wrong. Connection for the electric power of main shaft motor is wrong.
E799	Thread trimming operation time-out	<ul style="list-style-type: none"> The thread trimmer control operation is not completed within the predetermined time period. 	
E808	Solenoid short circuit	<ul style="list-style-type: none"> Solenoid power does not become normal voltage. 	<ul style="list-style-type: none"> Check whether the machine head cord is caught in the pulley cover or the like.
E809	Holding motion failure	<ul style="list-style-type: none"> Solenoid is not changed over to holding motion. 	<ul style="list-style-type: none"> Check whether the solenoid is abnormally heated. (CTL circuit board asm. circuit is broken.)
E810	Solenoid current abnormality	<ul style="list-style-type: none"> Solenoid rare short-circuit. 	<ul style="list-style-type: none"> Solenoid resistance.
E811	Overvoltage	<ul style="list-style-type: none"> When voltage higher than guaranteed one is inputted. 220V is applied to 120V box. CE : 400V is applied to 230V box. 	<ul style="list-style-type: none"> Check whether the applied power voltage is higher than the rated voltage + (plus) 10% or more. The power PCB may have broken.

No.	Description of error detected	Cause of occurrence expected	Items to be checked
E813	Low voltage	<ul style="list-style-type: none"> • When voltage lower than guaranteed one is inputted. • 120V is applied to 220V box. 	• Check whether the voltage is lower than the rated voltage - (minus) 10% or less.
		<ul style="list-style-type: none"> • Inner circuit is broken by the applied overvoltage. 	• Check whether fuse or regenerative resistance is broken.
E922	Main shaft uncontrollable	<ul style="list-style-type: none"> • In the case the main shaft cannot be controlled. 	
E924	Motor driver failure	<ul style="list-style-type: none"> • Motor driver has broken. 	
E930	Faulty encoder	<ul style="list-style-type: none"> • In the case a motor signal cannot be input correctly. 	<ul style="list-style-type: none"> • Check the motor signal connector (CN30) for looseness and slip-off. • Check whether the motor signal cord is caught in the machine head or has a break.
E931	Motor hole sensor failure		
E942	Faulty EEPROM	<ul style="list-style-type: none"> • Data cannot be written on the EEPROM. 	